

THE ROYAL

**SUBSTRUCTURES OF THE THIRD
DYNASTY**

REMINDERS, REMARKS AND EPITOME
(Feb. 2015)

KINGS OF THE THIRD DYNASTY

NEW KINGDOM NAMES OF KINGS

#	Abydos	Saqqara	Turin	Turin Reigns
1	# 15 Nebka	Om	# 3-4 Nebka	19 years
2	# 16 Djeser sa (Setesh)	# 12 Djeser	# 3-5 Djeserit (in red ink)	19 years
3	# 17 Teti	Om	Om	Om
4	# 18 Sedjes ²⁸	Om	Om	Om
5	# 18 Sedjes	Om	Om	Om
6	# 18 Sedjes	# 13 Djeserteti	# 3-6 Djeserty	6 monthes
7	# 18 Sedjes	# 14 Nebkara	# 3-7 Hudjefa ²⁹	Within 6 y. of Hudjefa
8	# 19 Neferkara	Om	# 3-7 Hudjefa	Within 6 y. of Hudjefa
9	Om	# 15 Huni	# 3-8 Huni	24 years

MANETHO'S NAMES AND LENGTHS OF REIGNS OF KINGS

#	Manetho Af.	Af.'s Reigns	Manetho Eu.	Manetho Er.	Er's Reigns
1	# 1 Necherophis	28 years	Nechrochris	Om	Om
2	# 2 Tosorthros	29 years	Sesorthos	Om	Om
3	# 3 Tyreis	07 years	Om	Om	Om
4	# 4 Mesochris	17 years	Om	# 6 Momcheiri	79 years
5	# 5 Soyphis	16 years	Om	# 7 Stoichos	06 years
6	# 6 Tosortasis	19 years	Om	# 8 Gosormies	30 years
7	# 7 Akhes	42 years	Om	# 9 Mares	26 years
8	# 8 Sephuris	30 years	Om	# 10 Anoyphis	20 years
9	# 9 Kerpheris	26 years	Om	Om	Om

CONTEMPORARY MATERIAL

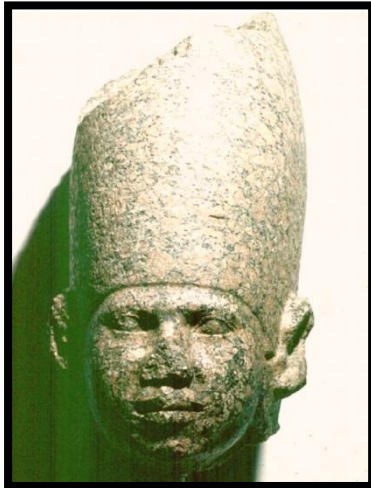
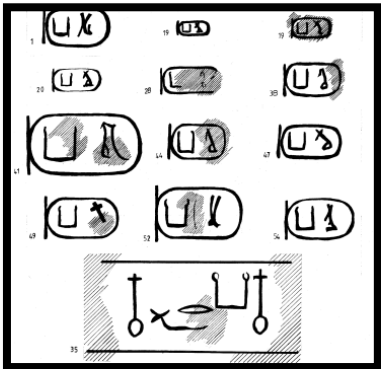
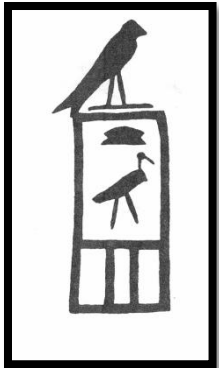
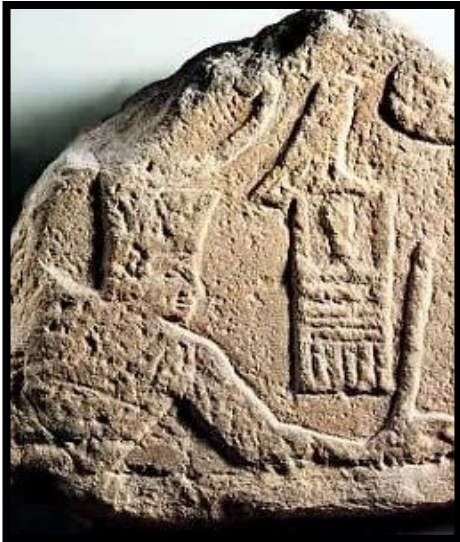

INFORMATION PROVIDERS



J. E. QUIBELL



C. M. FIRTH



J. PH. LAUER



BRUNO DESLANDES



SELIM HASSAN



ZAKI SAAD

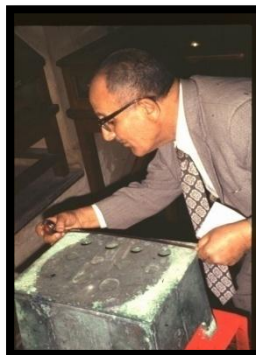

ZAKI ISKANDER

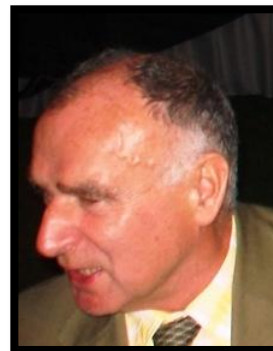

KAROL MYOELIWIEC



AHMED MOUSSA



TOMASZ HERBICH



J. GARSTANG



ZAKARIA GOMEIM



D. DUNHAM

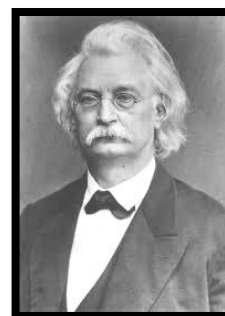

RICHAR LESIUS



A. BARSANTI



SAKUJI YOSHIMURA

MONUMENT SITES

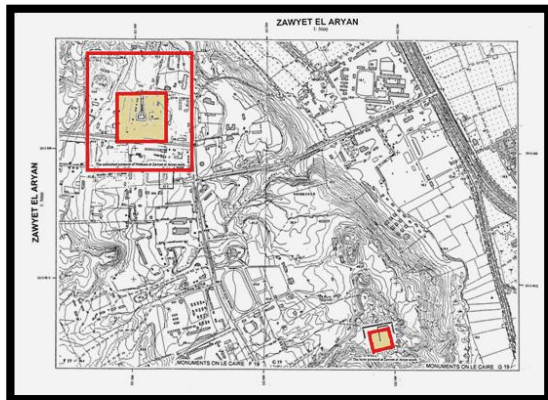
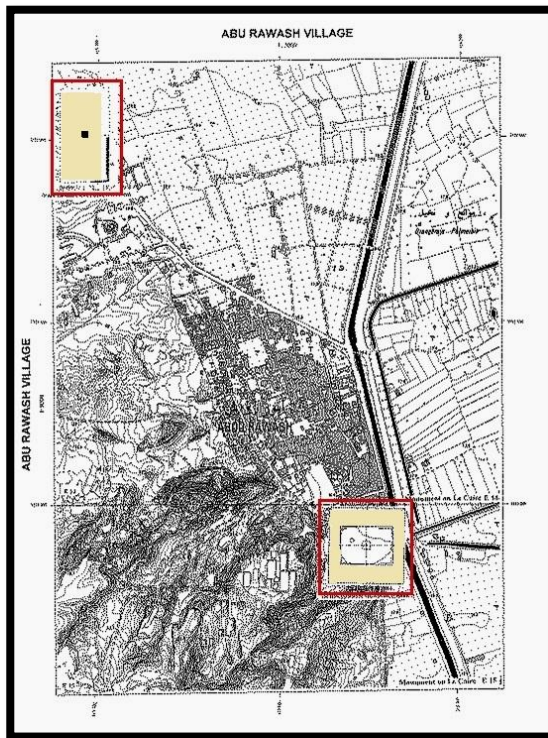



REMINDER THE STEP PYRAMID COMPLEX

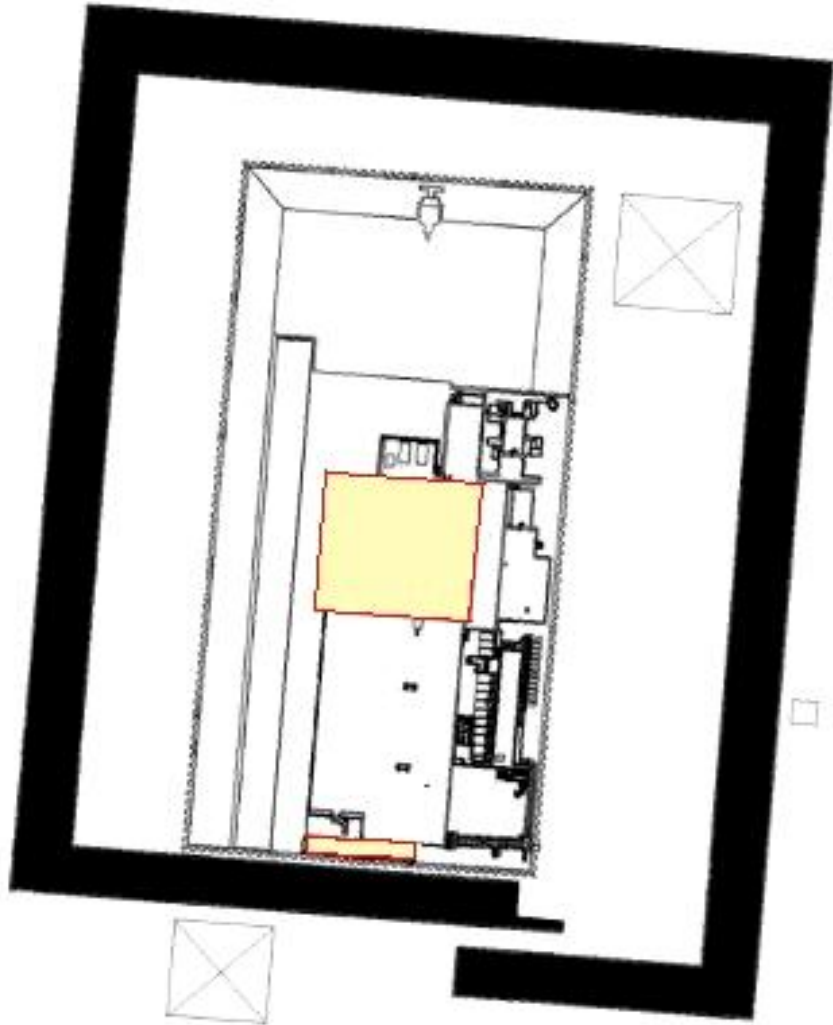

REMINDER

THE SOUTH TOMB SUBSTRUCTURES

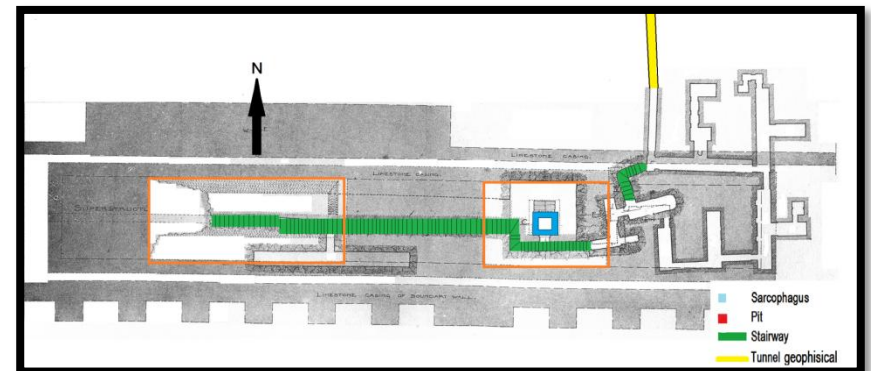
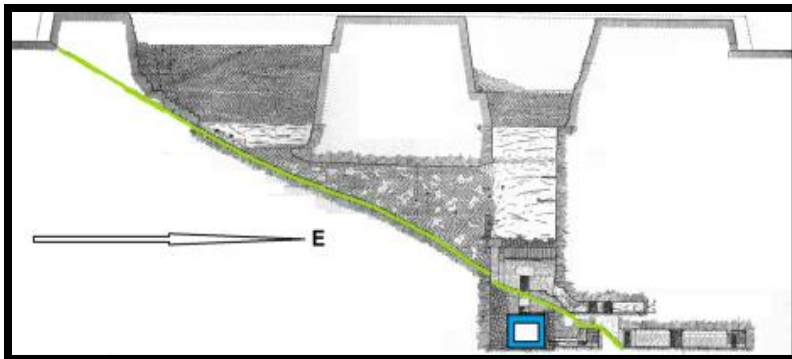

REMINDER THE STEP PYRAMID SUBSTRUCTURES

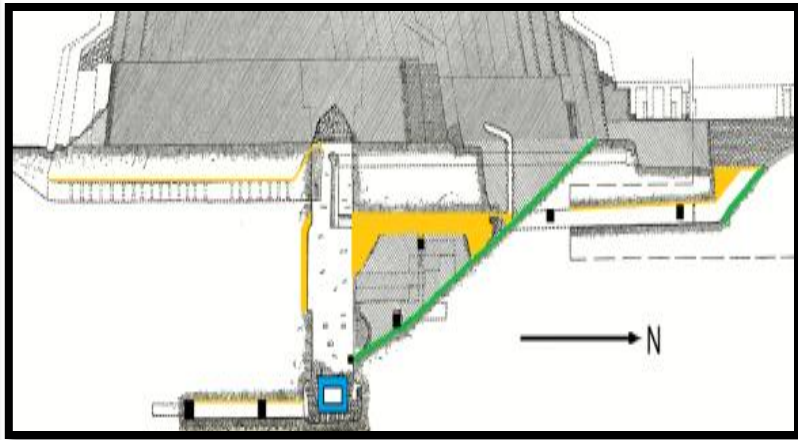
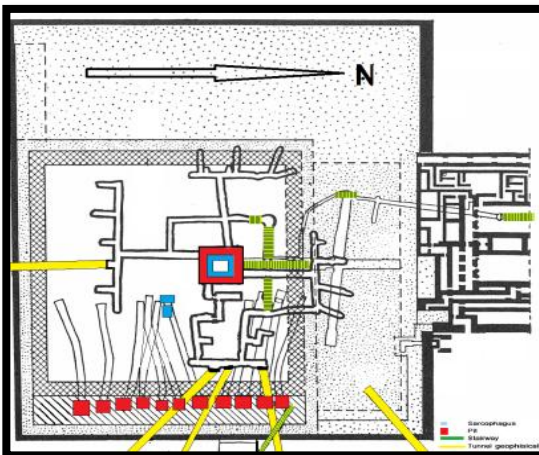
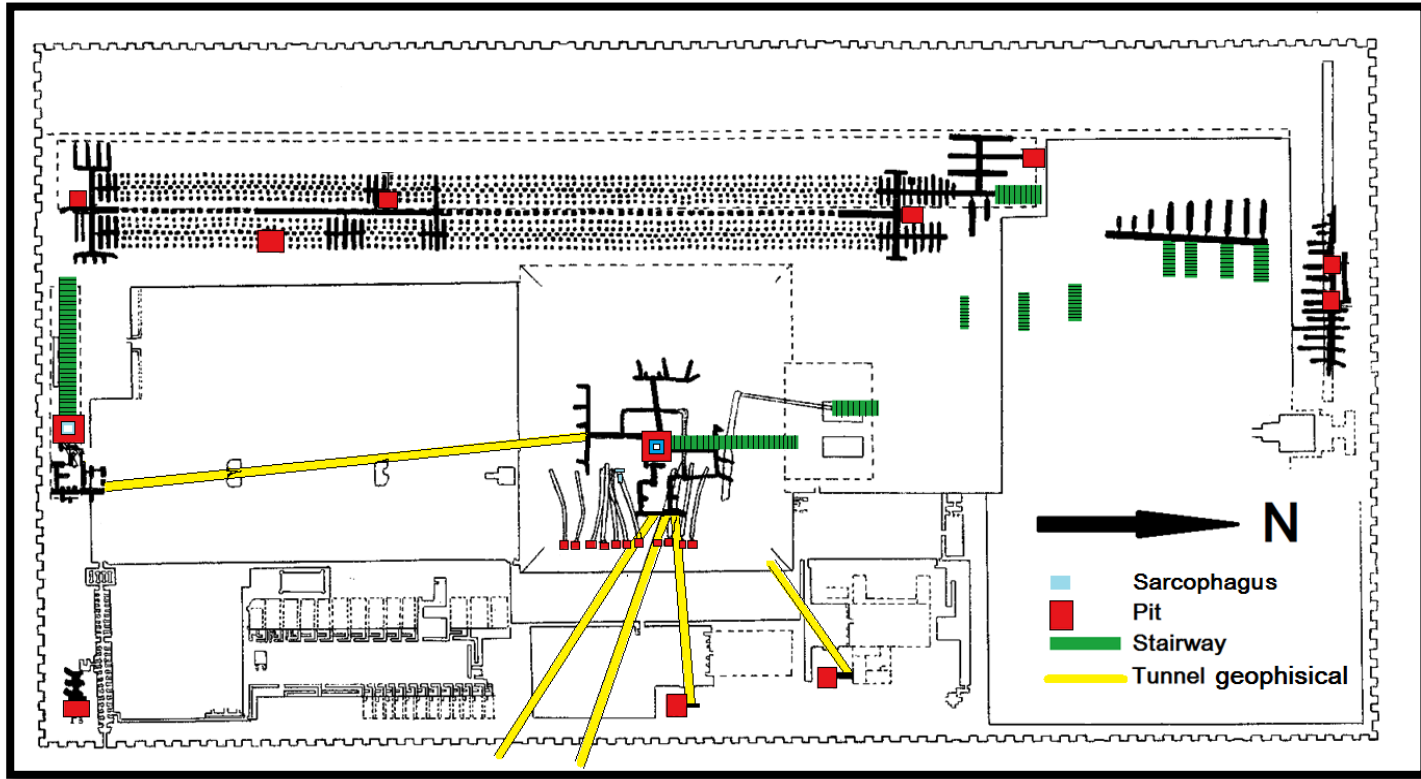

REMINDER THE DRY MOAT

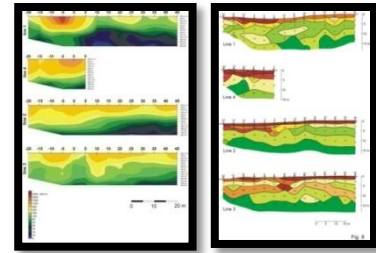
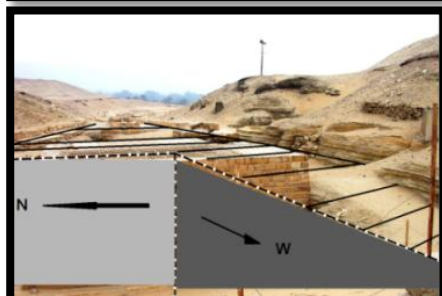
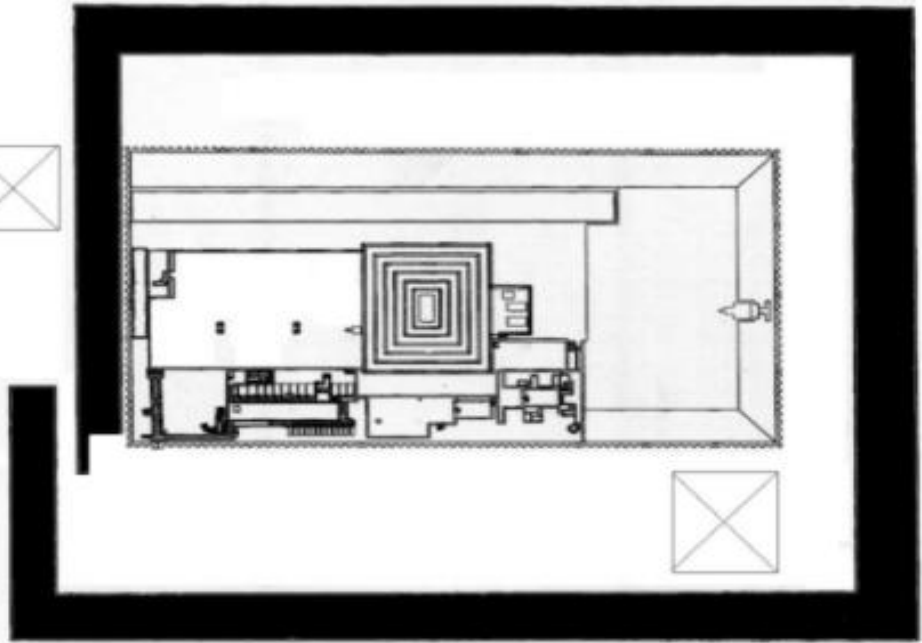
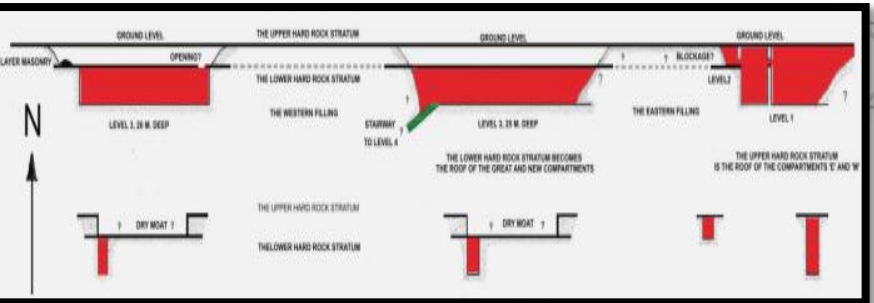
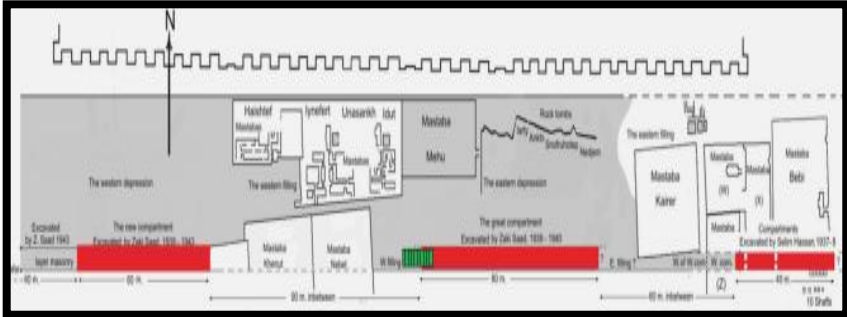

REMINDER

BET KHALLAF K1 and K2 SUBSTRUCTURES

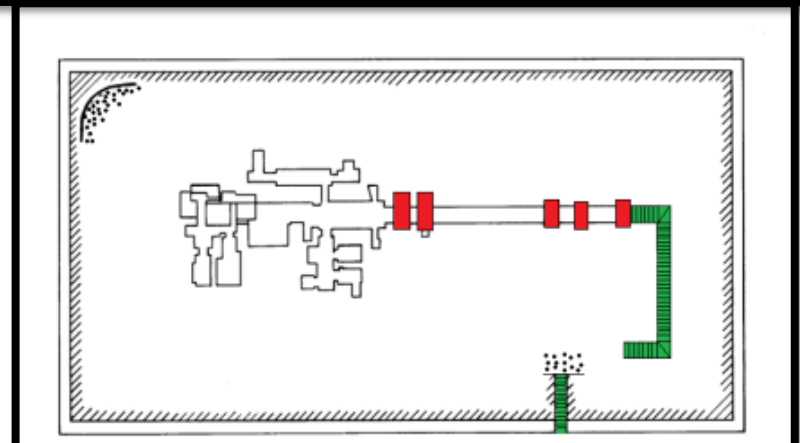
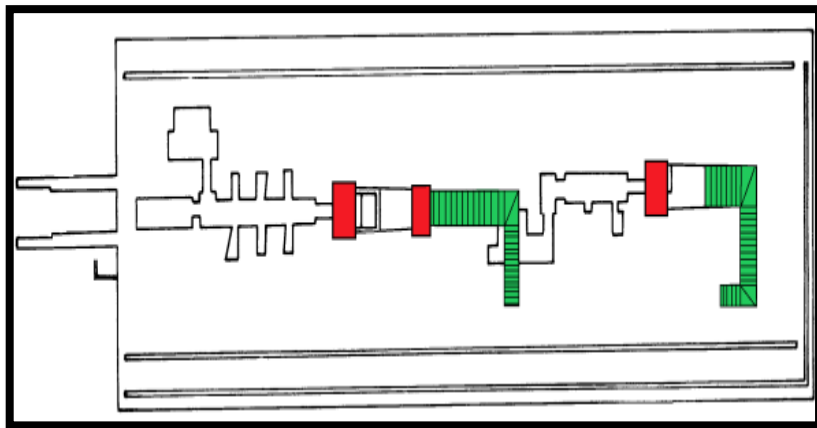
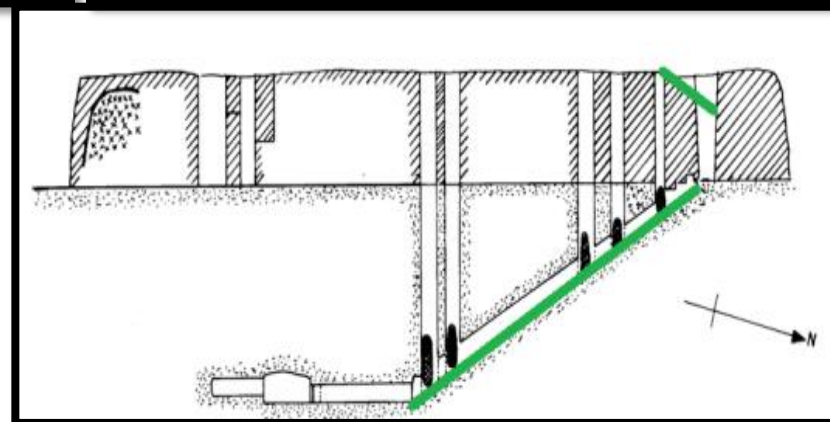
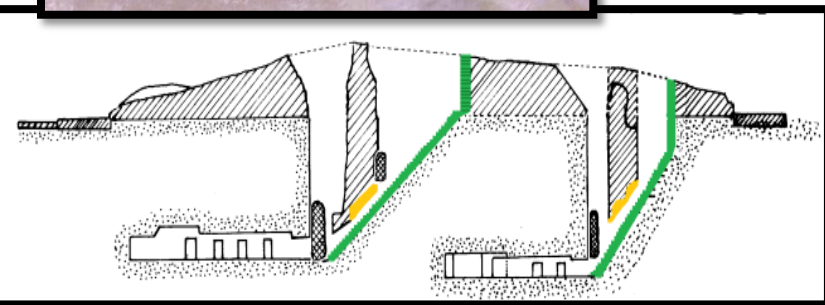
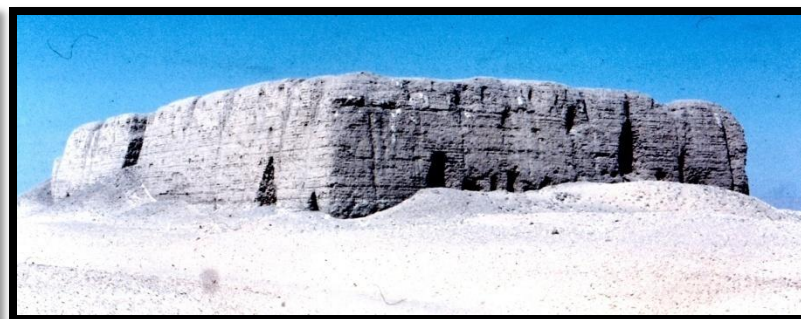
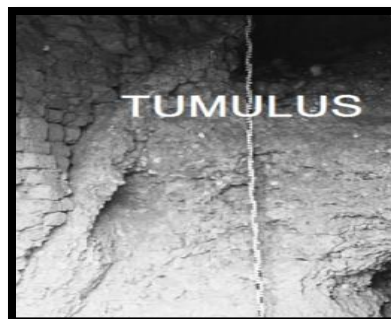

REMINDER SEKHEMKHET SUBSTRUCTURES

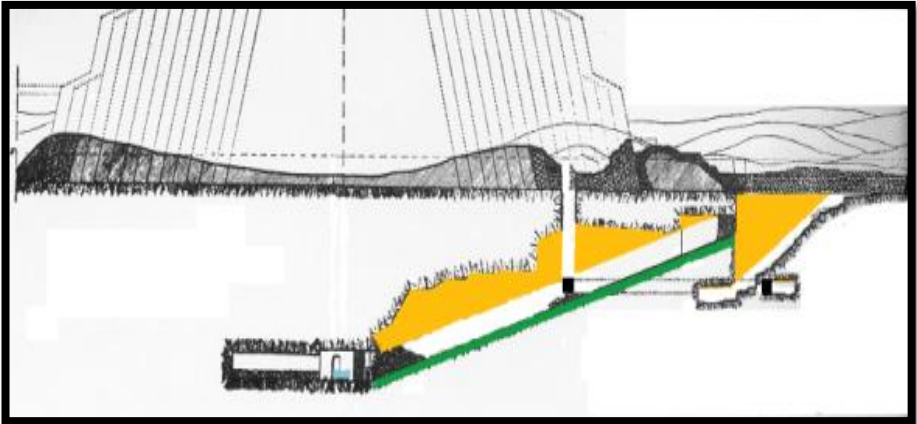
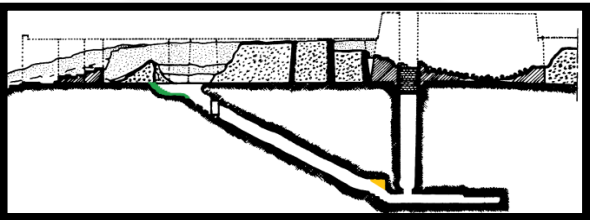
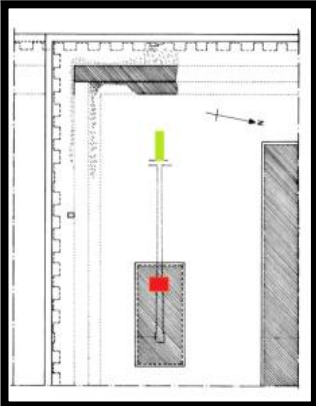
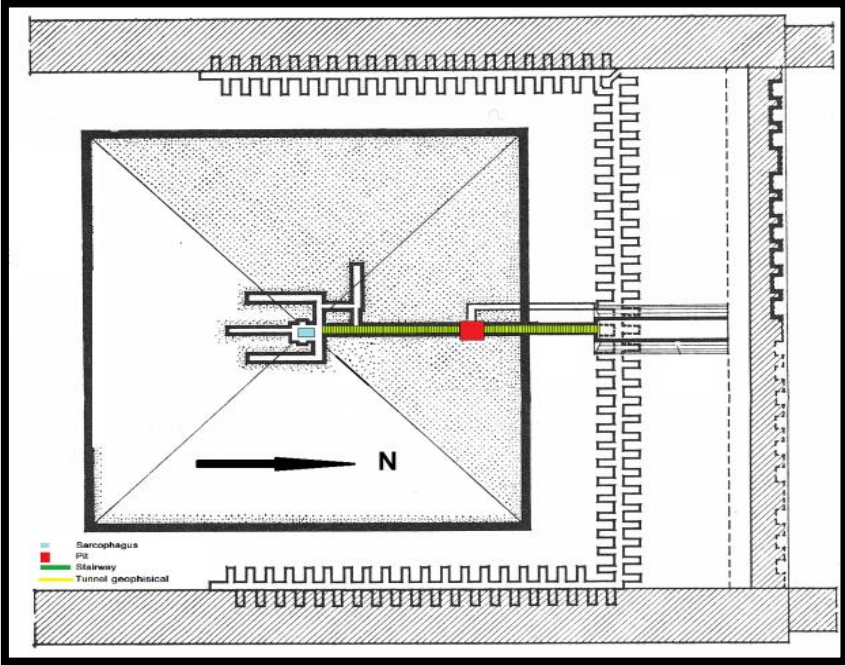

REMINDER

ZAWYER EL ARYAN SOUTH

SUBSTRUCTURES

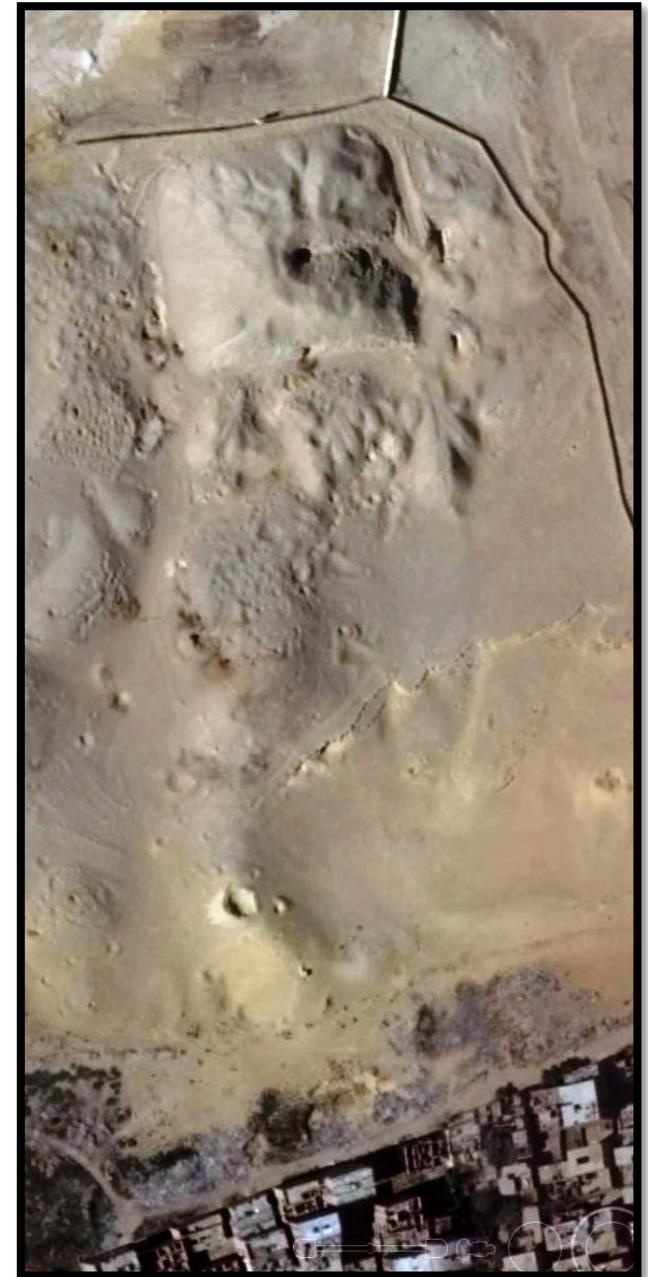
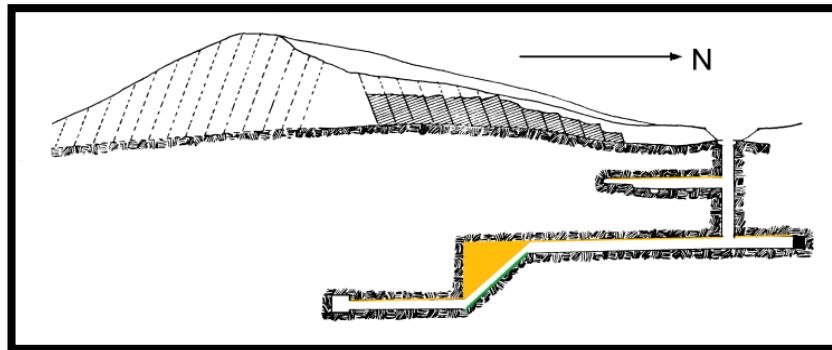
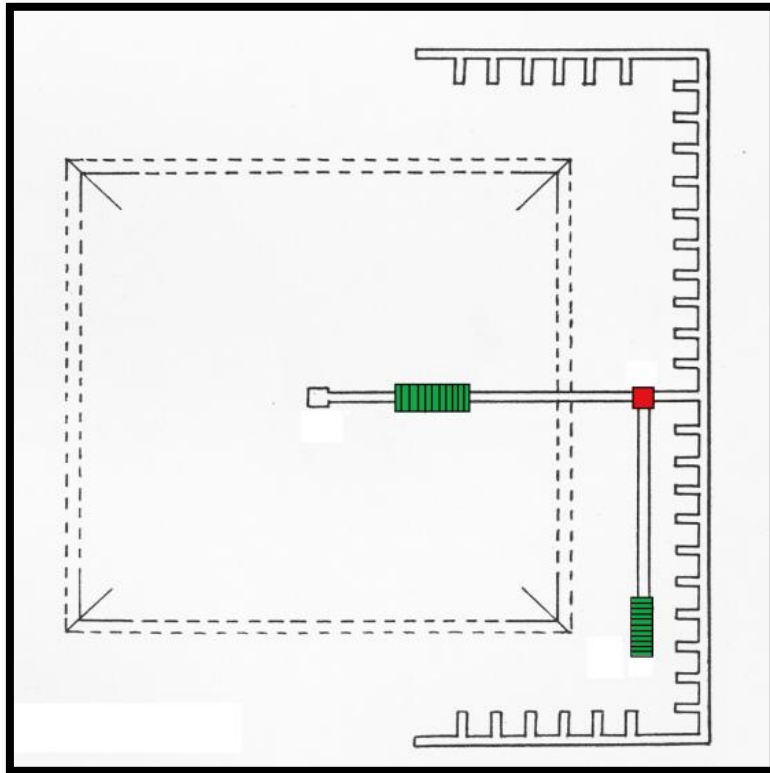

REMINDER

BRICK PYRAMID AT ABU RAWASH SUBSTRUCTURE

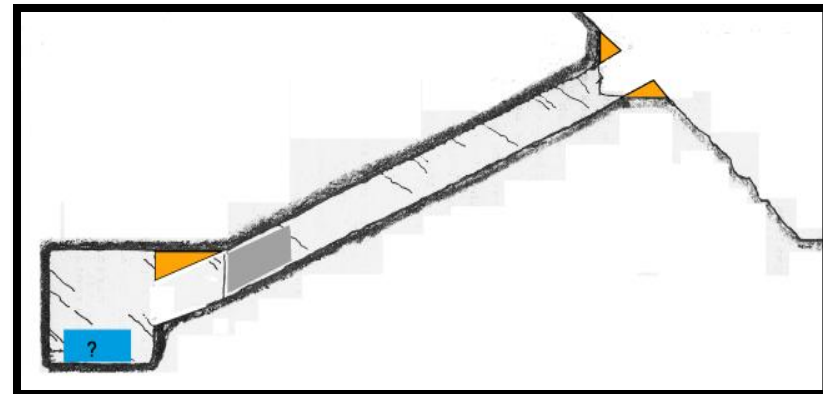
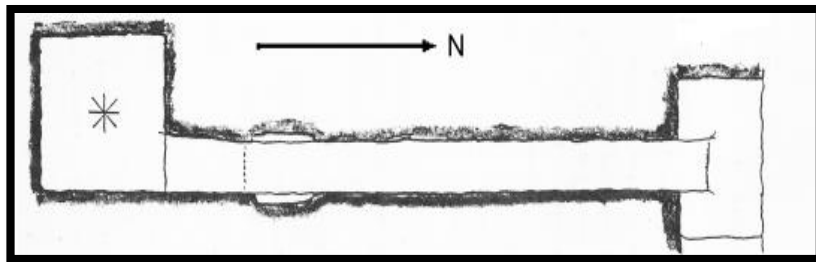
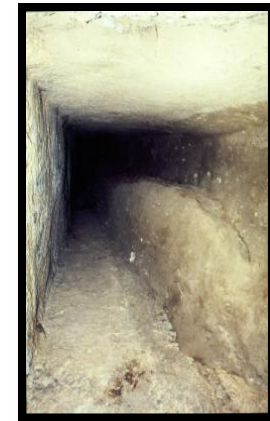
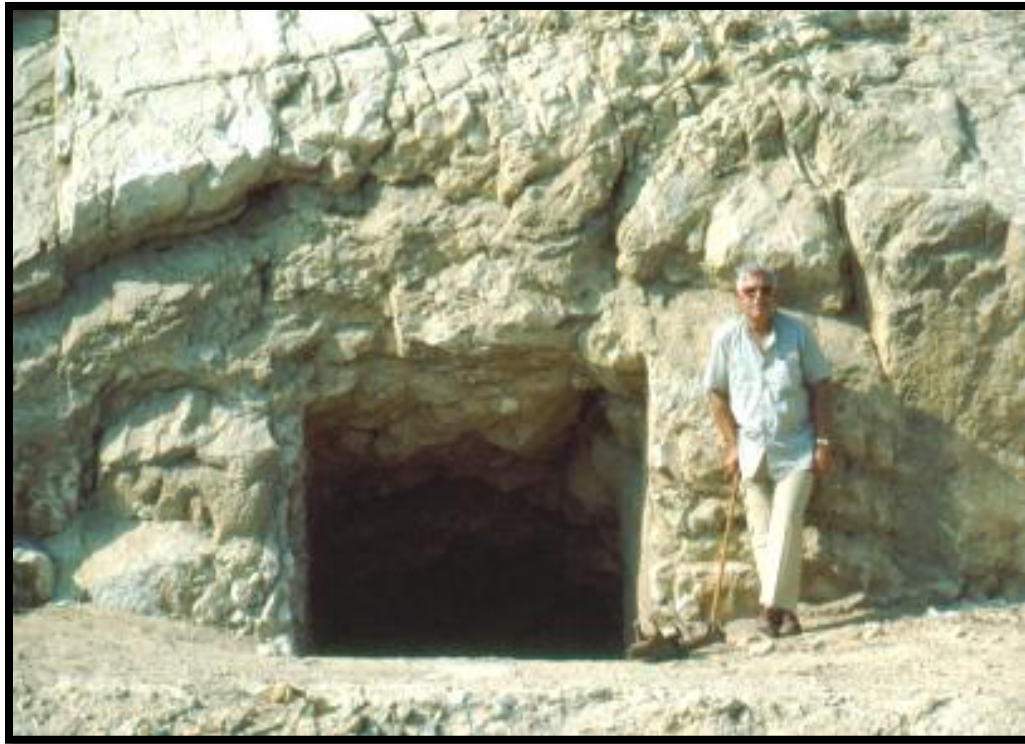

REMINDER

ZAWYET EL ARYAN NORTH SUBSTRUCTURE

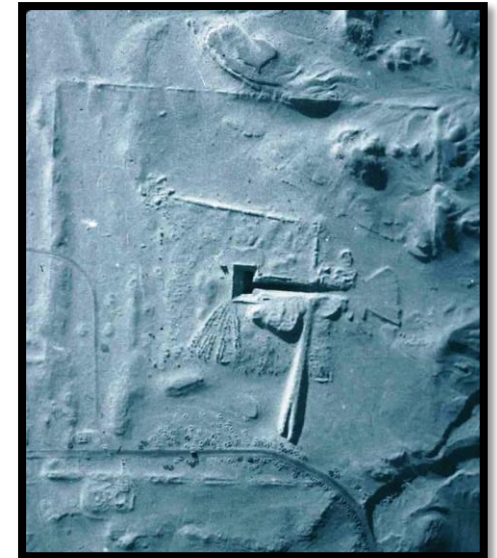
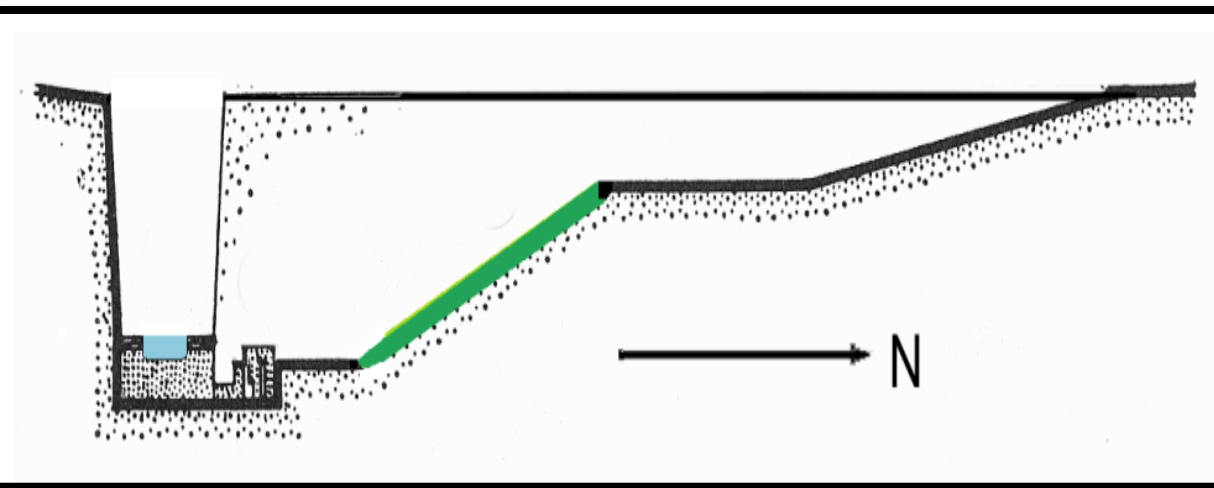
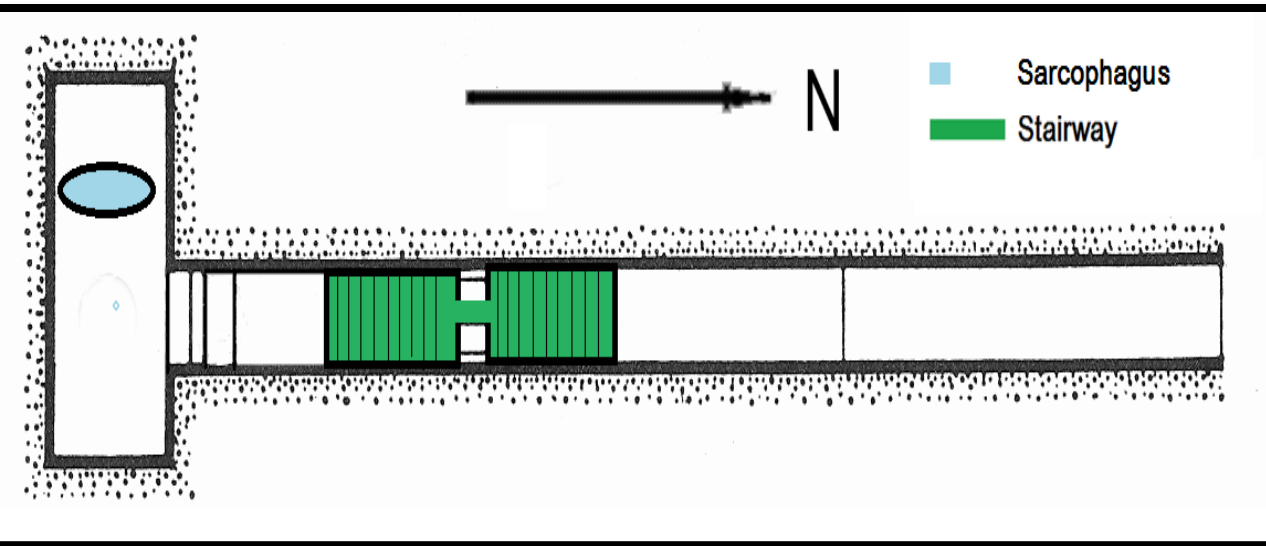

REMINDER

SUBSTRUCTURE AT NORTH-WEST SAQQARA

HILL-SIDE

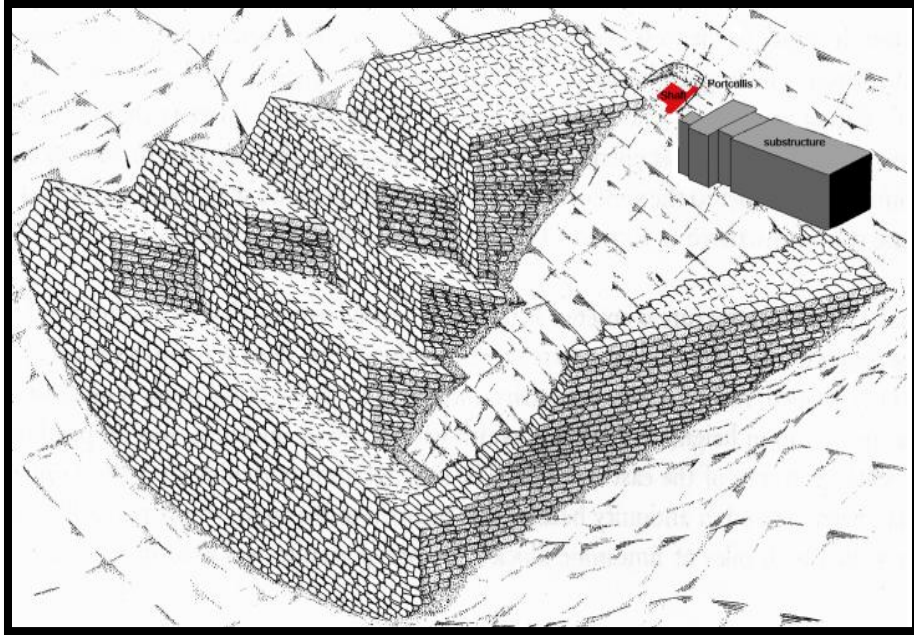
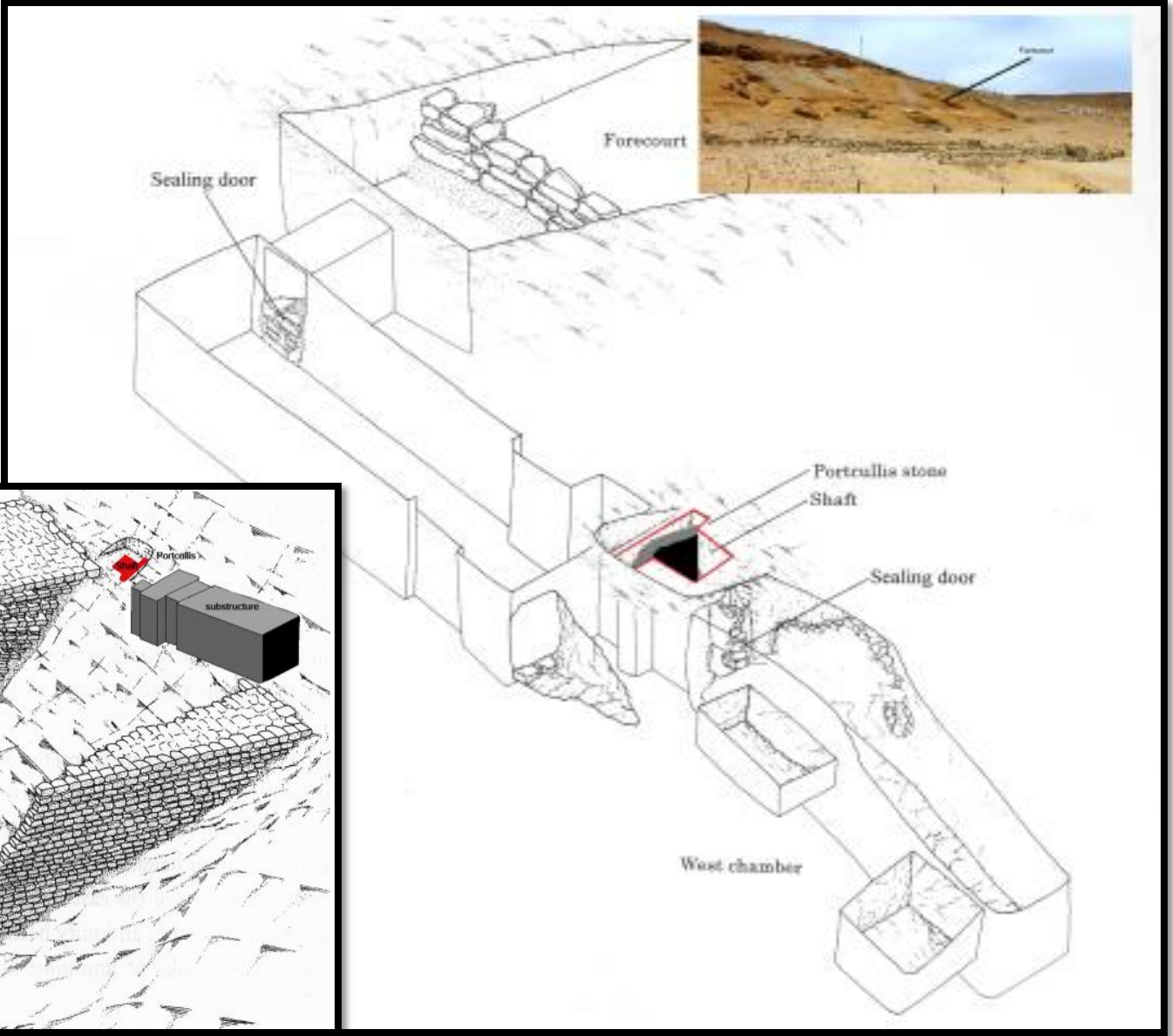

REMARKS

SUBSTRUCTURES BEFORE AN ENTRANCE

ACCRETION WEDGE BLOCK

AT THE STEP PYRAMID AND THE SOUTHERN TOMB

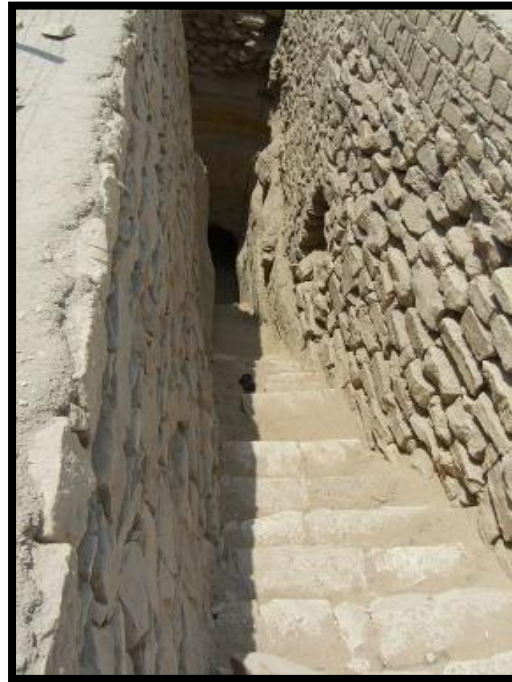

REMARKS

SUBSTRUCTURES BEFORE AN ENTRANCE

ACCRETION WEDGE BLOCK AT K1

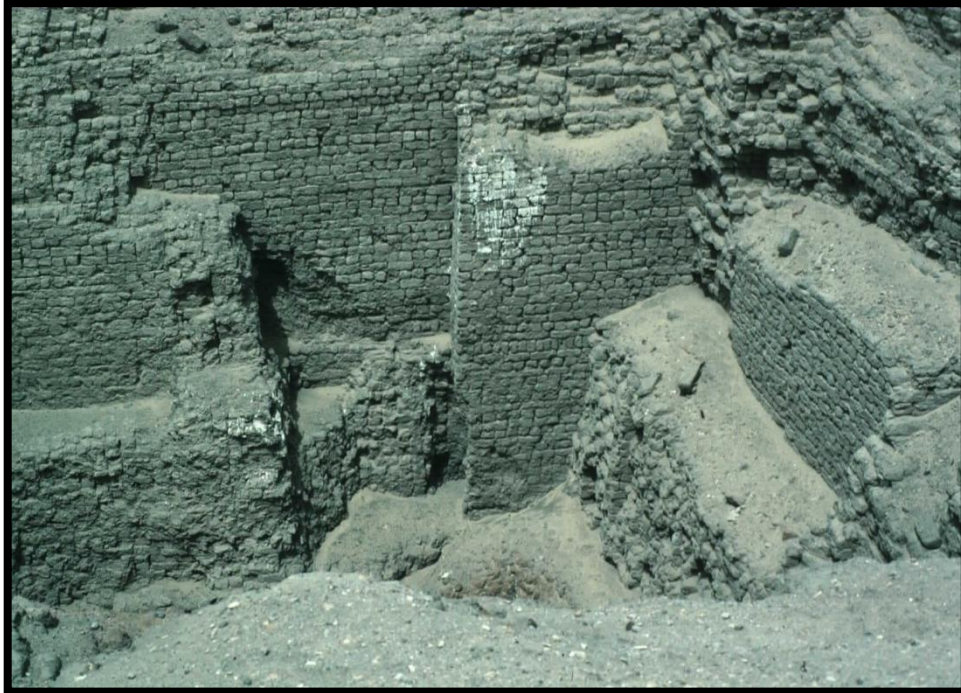

REMARKS

SUBSTRUCTURES BEFORE AN ENTRANCE

ACCRETION WEDGE BLOCK AT SEKHEMKHET



REMARKS

SUBSTRUCTURES BEFORE AN ENTRANCE

ACCRETION WEDGE BLOCK AT Z EL ARYAN NORTH

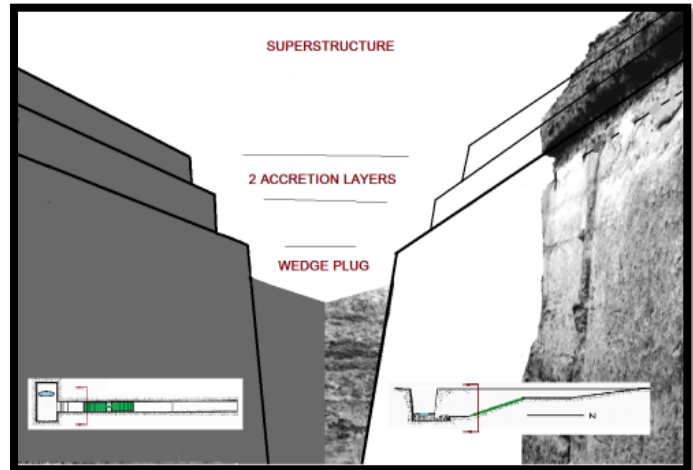

REMARKS

SUBSTRUCTURES BEYOND AN ENTRANCE

BURIAL CHAMBERS AT THE BOTTOM OF A SHAFT

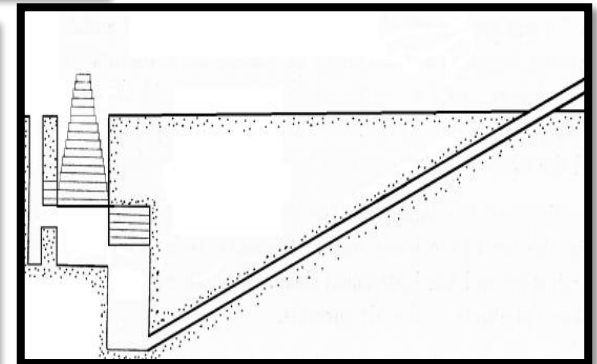
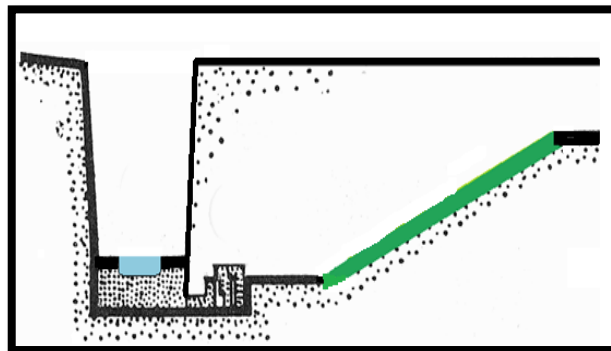
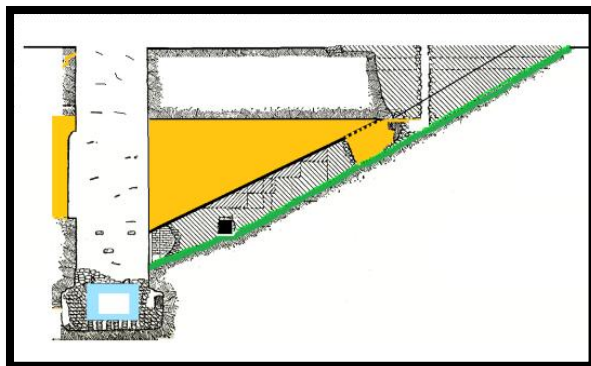
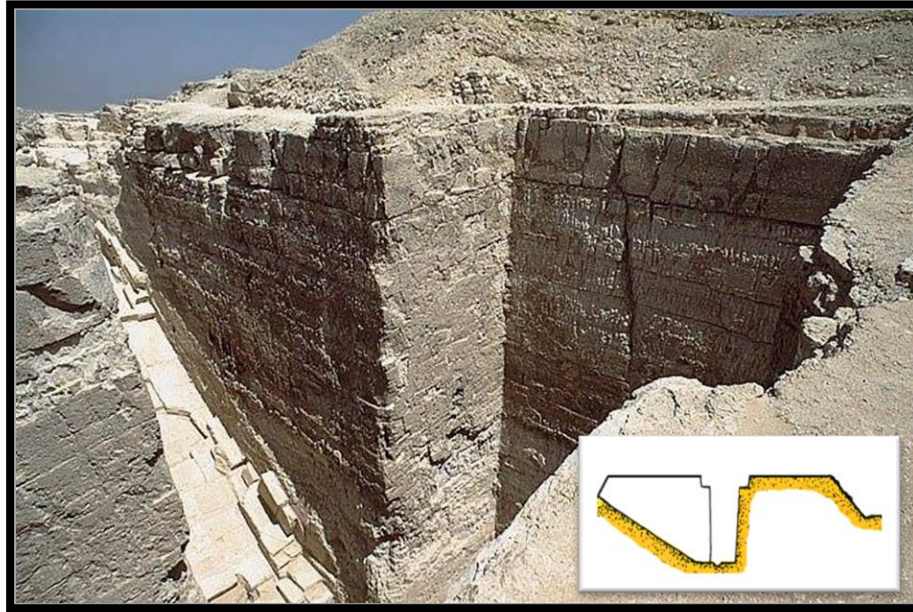

REMARKS

SUBSTRUCTURES BEYOND AN ENTRANCE ROCK CUT BURIAL CHAMBERS

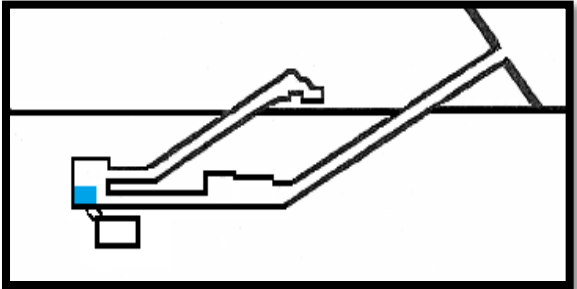
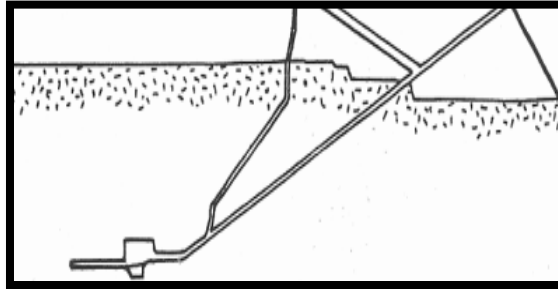
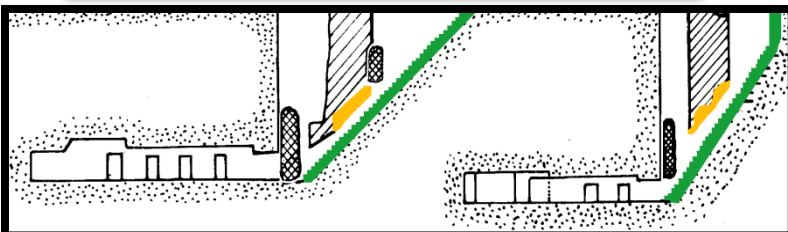
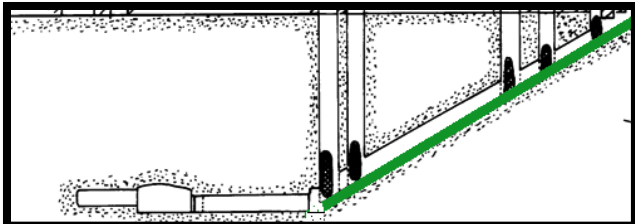

REMARKS

SUBSTRUCTURES BEYOND AN ENTRANCE INDEPENDANT

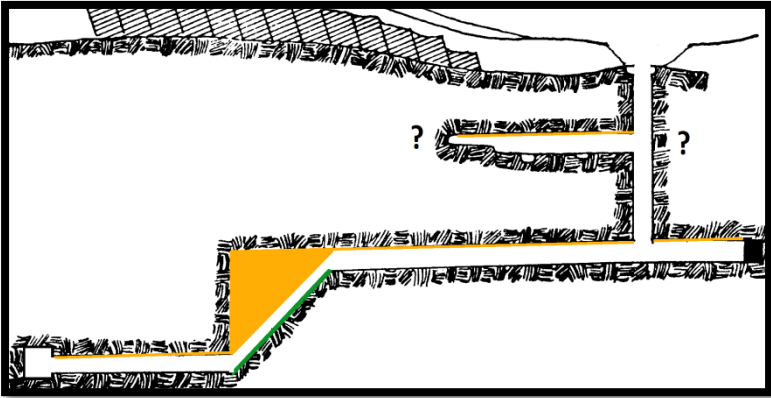
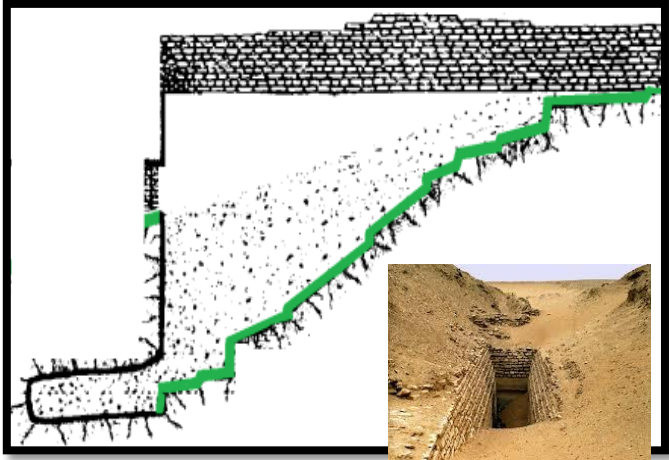
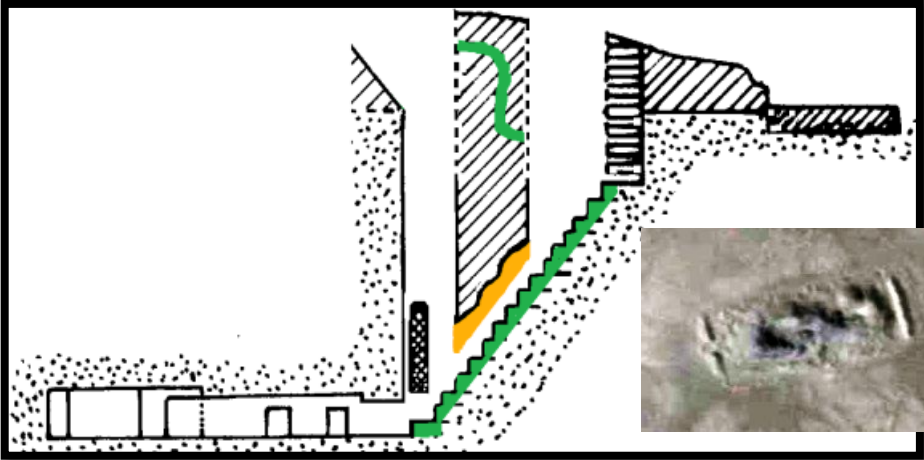

REMARKS

SUBSTRUCTURES BEYOND AN ENTRANCE DEVELOPMENT OF SARCOPHAGI

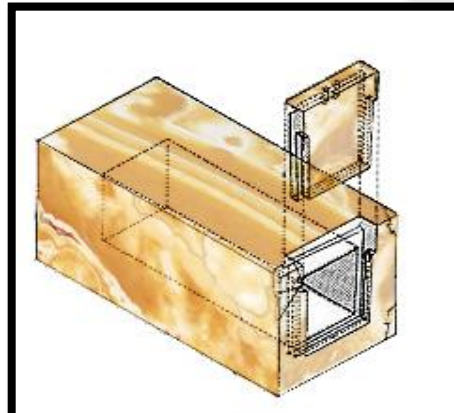
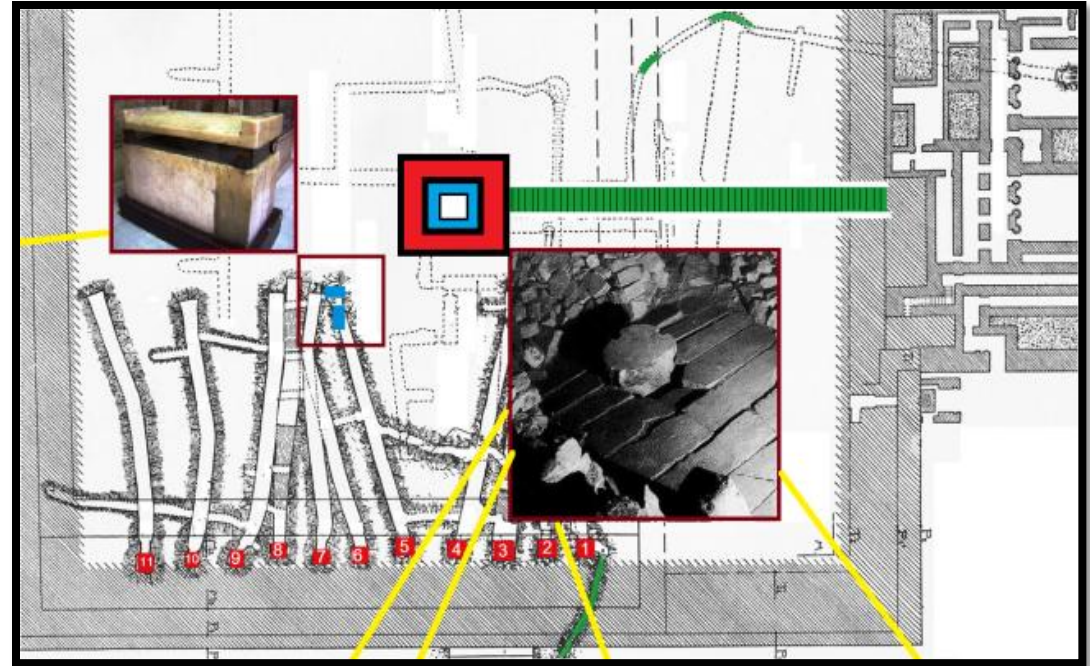
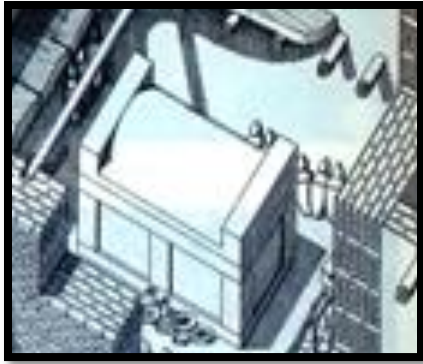

REMARKS WITHOUT SUBSTRUCTURES

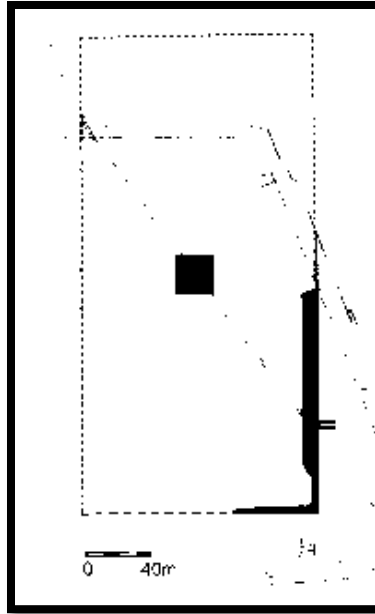
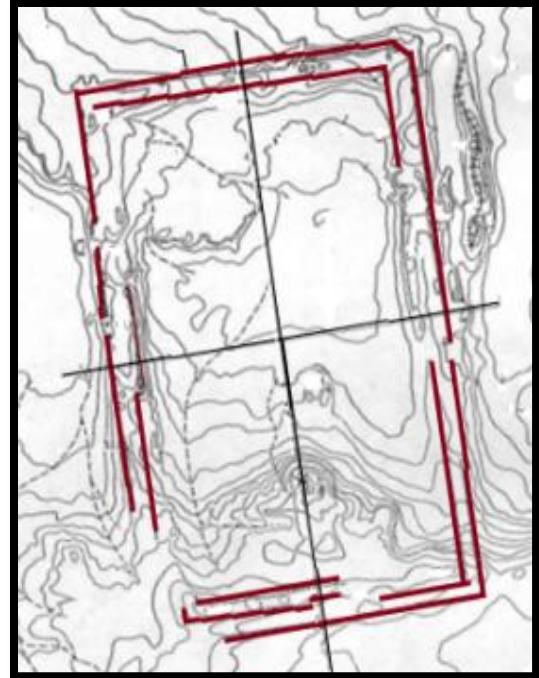
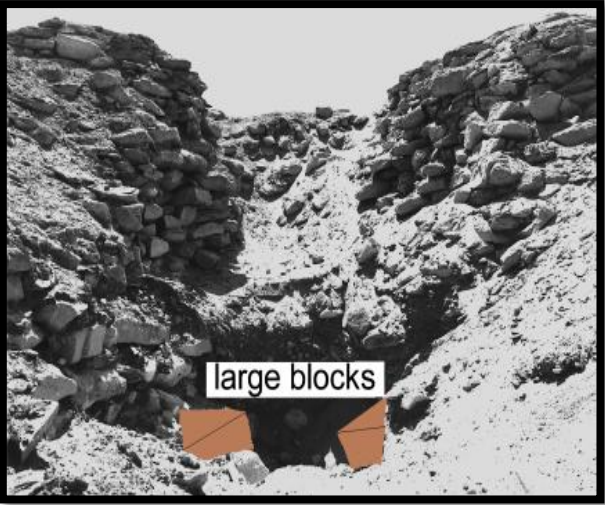
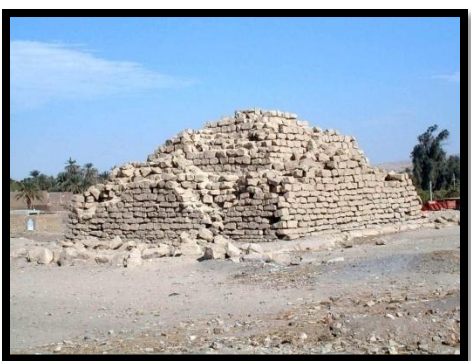

REMARKS THE INNER SOUTH CHANNEL

WINDOW PASSAGES AT THE EAST COMPARTMENT

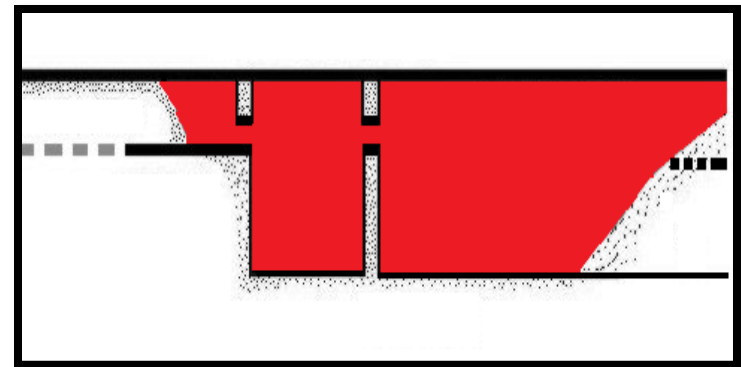
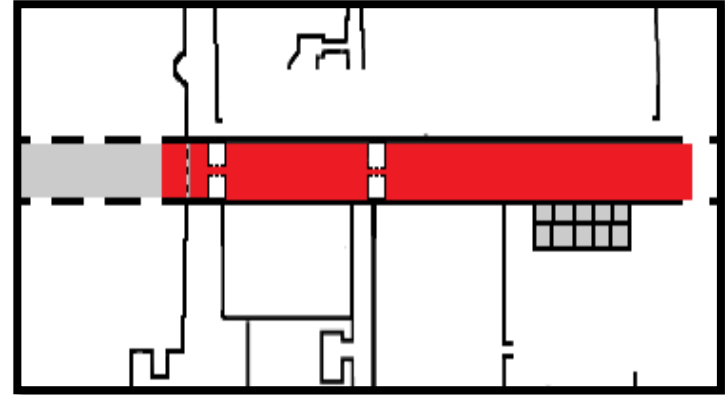
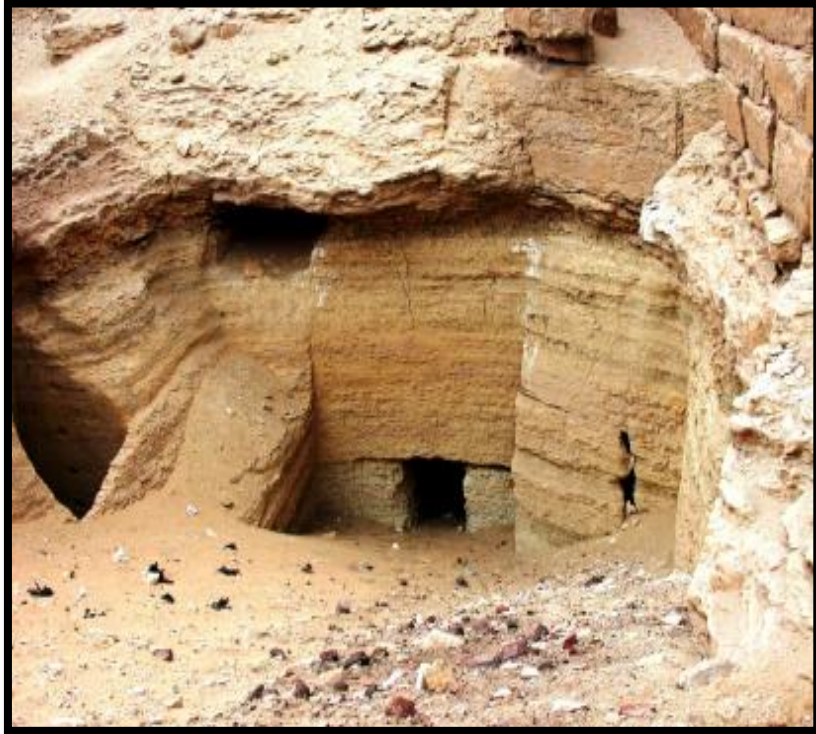

REMARKS THE INNER SOUTH CHANNEL

A STAIRWAY AT THE EAST COMPARTMENT

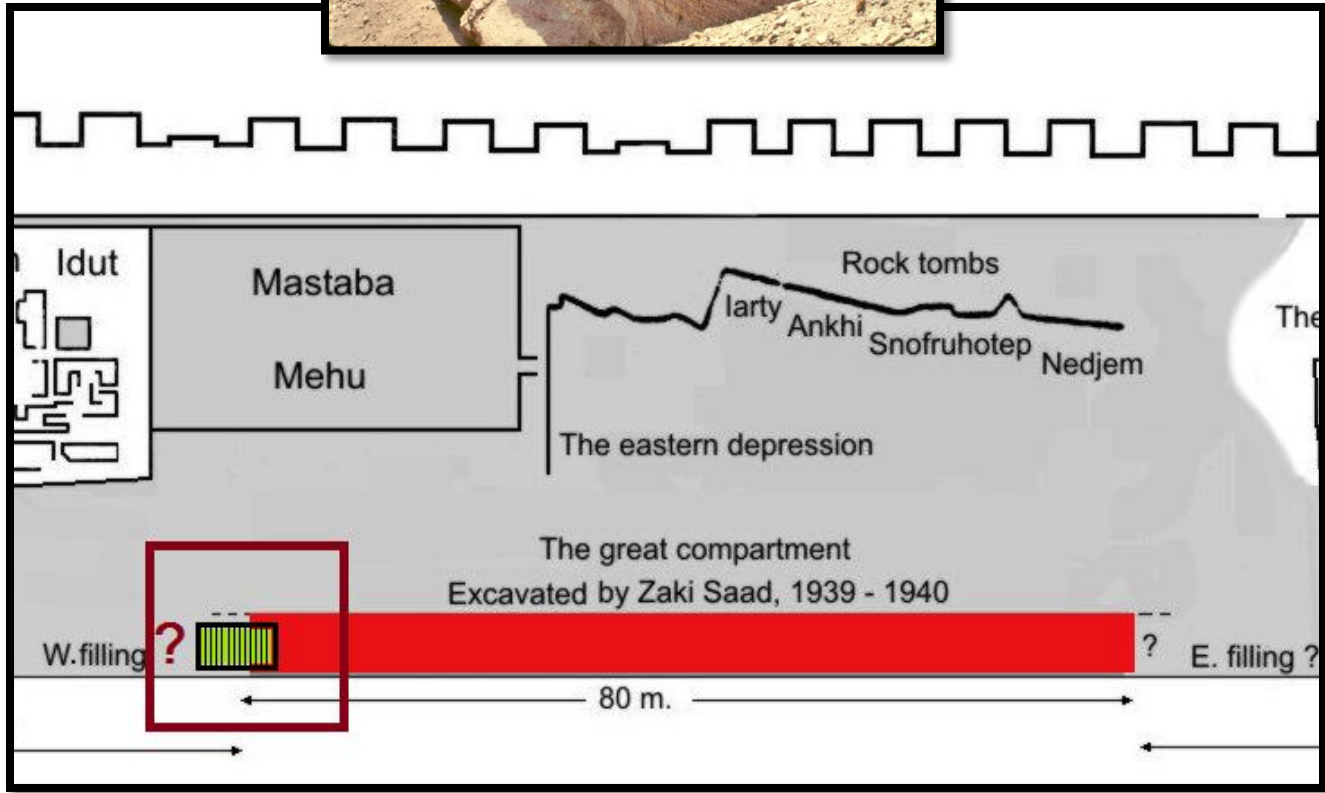
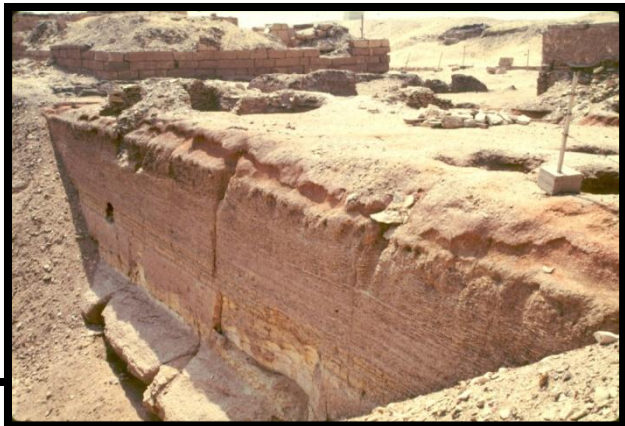

REMARKS THE INNER SOUTH CHANNEL

NICHES AT THE WEST COMPARTMENT

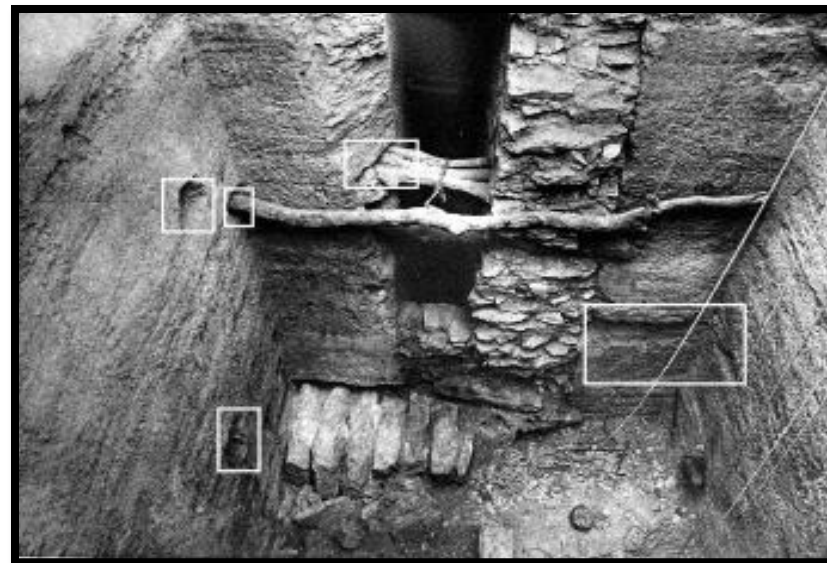
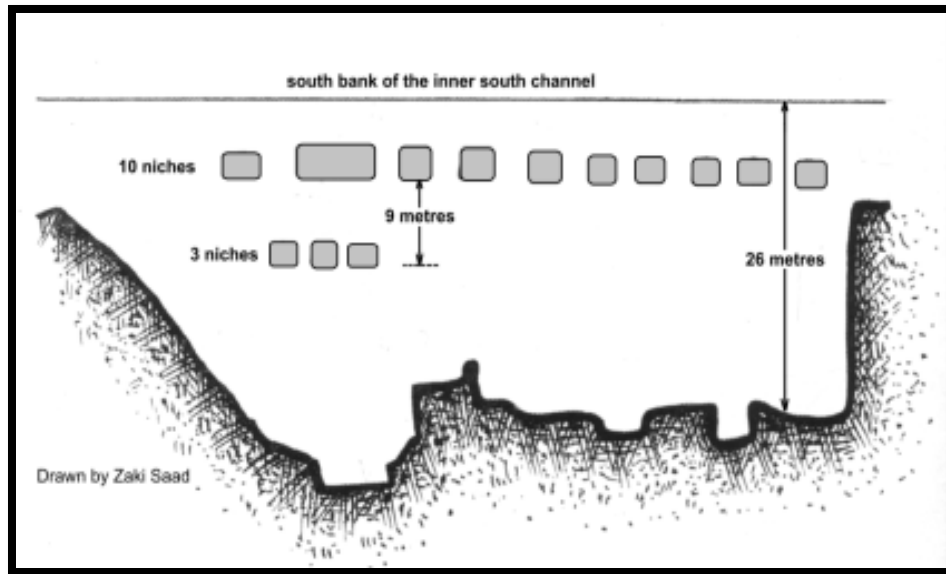

REMARKS THE INNER SOUTH CHANNEL

ACCRETION LAYER REMAINS AT THE WEST COMPARTMENT

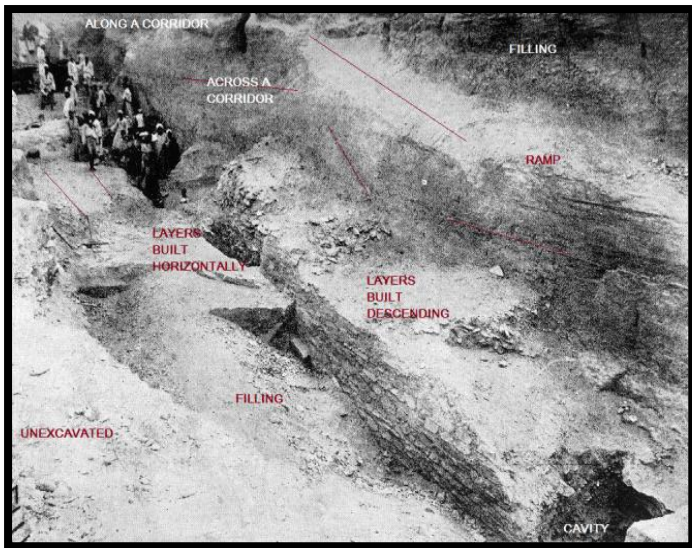
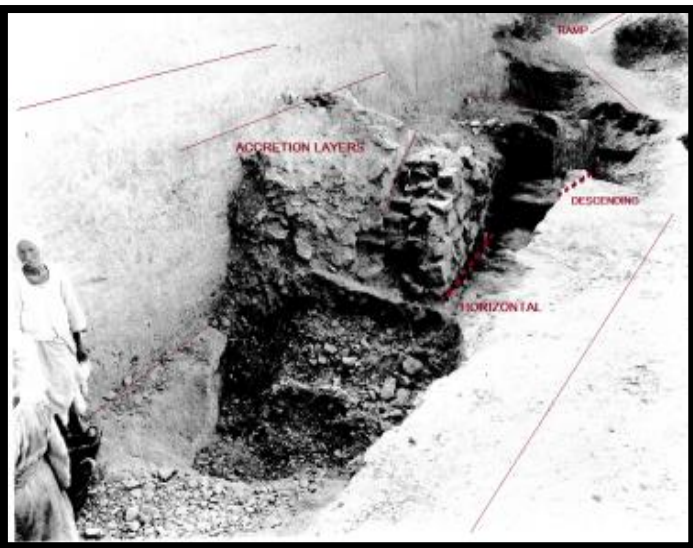

REMARKS THE INNER SOUTH CHANNEL

HYPOGEUM 1 AT THE WEST COMPARTMENT

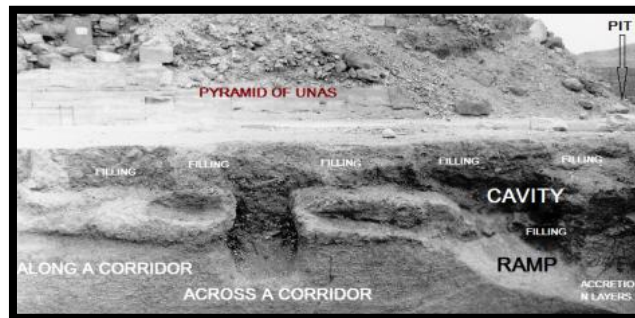
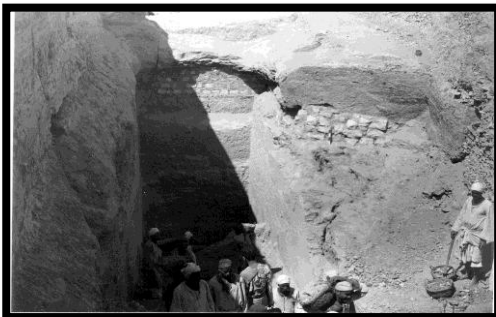
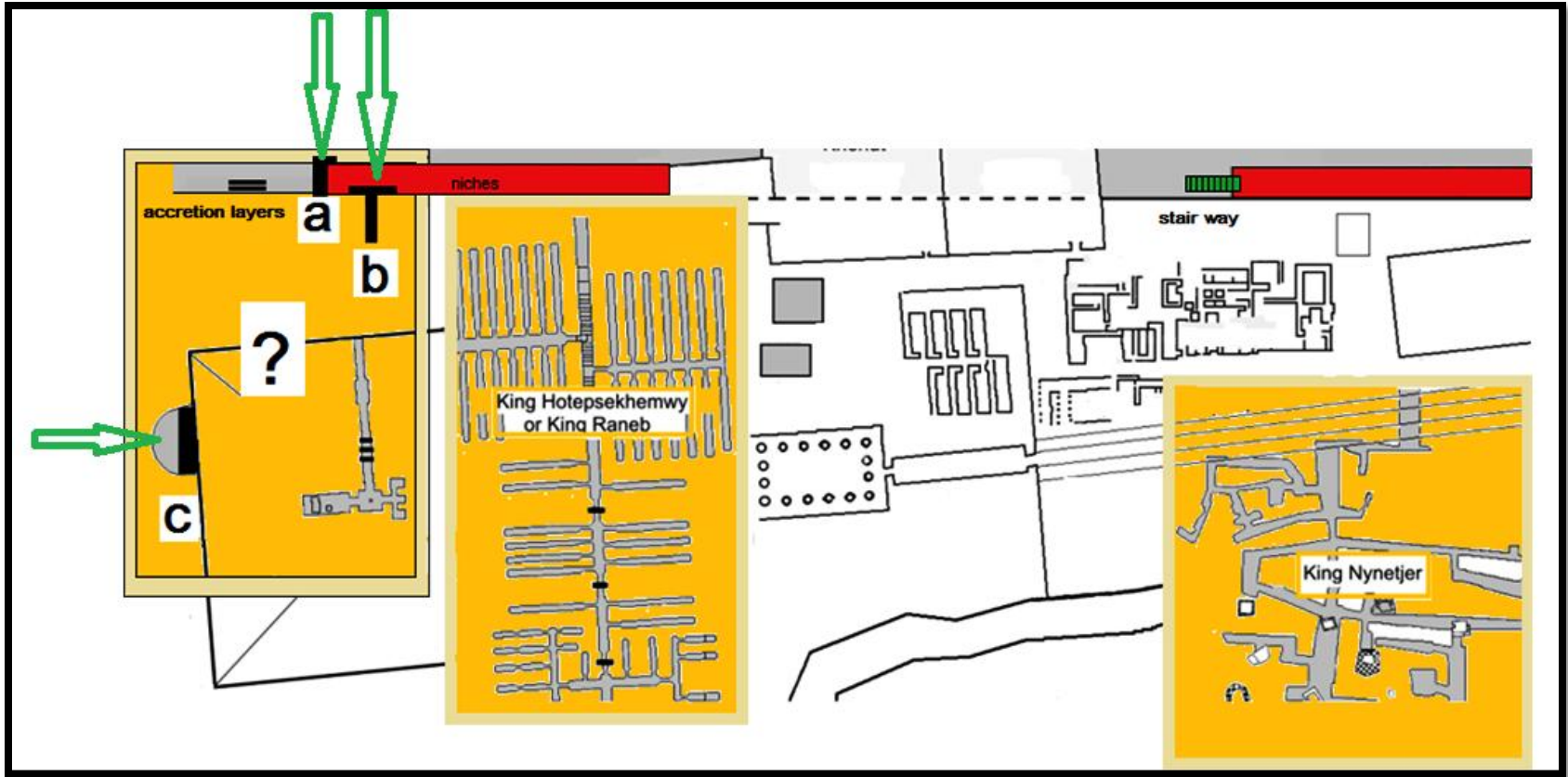

REMARKS

**THE INNER SOUTH CHANNEL
HYPOGEUM 2 AT THE EAST COMPARTMENT**

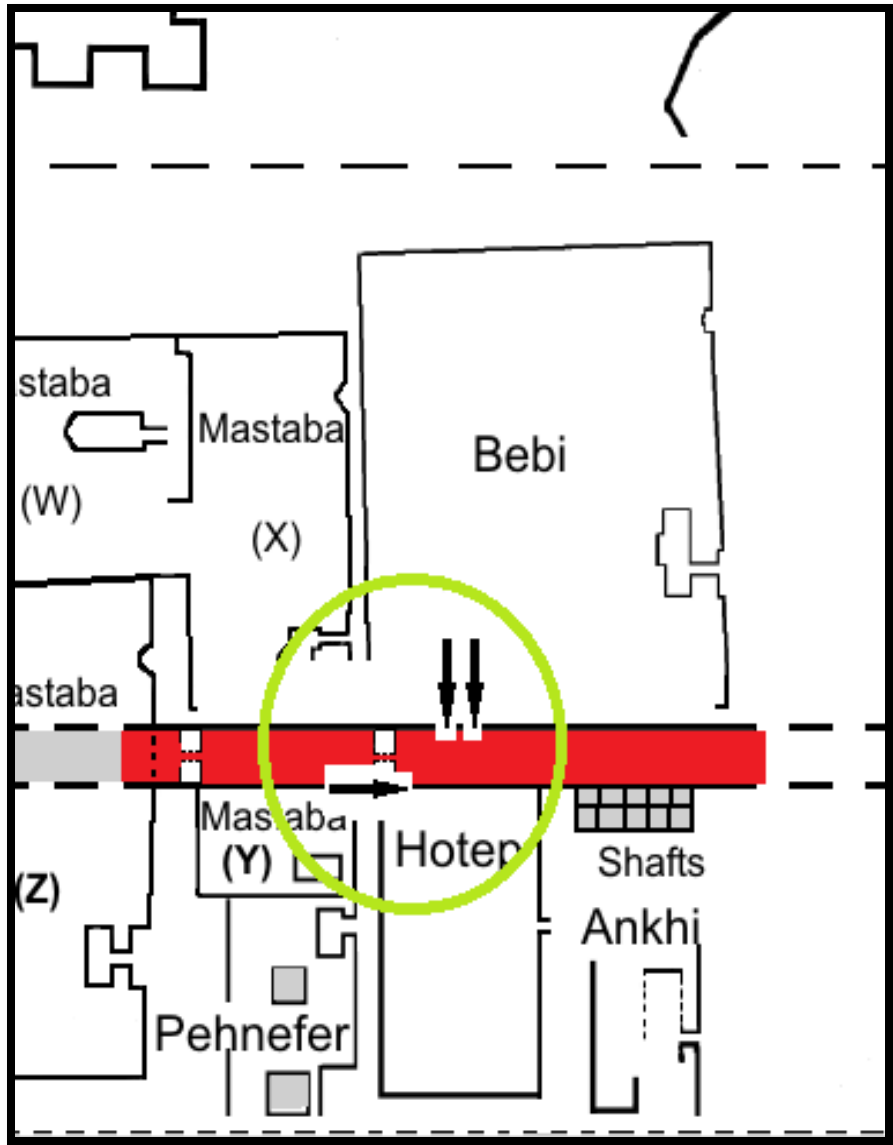

THE PYRAMID DESIGNERS

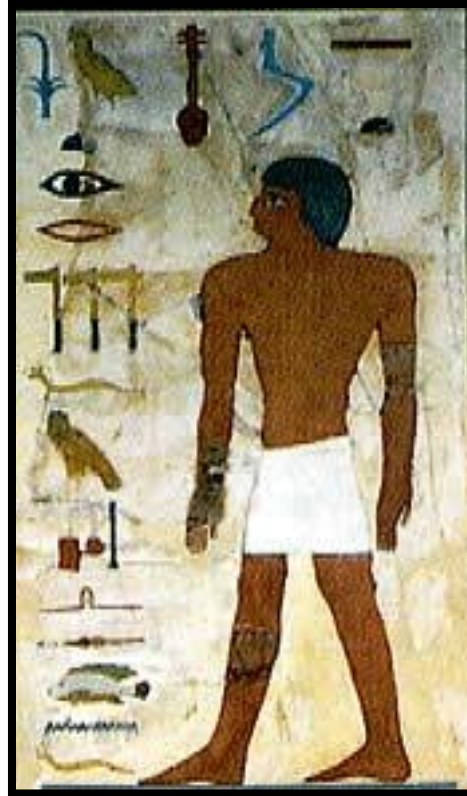

EPITOME

IT WAS **SAFE** TO PENETRATE THE BED ROCK

VERTICALLY FOR SHAFTS AND **HORIZONTALLY** FOR TUNNELS

BUT WAS UNSAFE TO PENETRATE THE BED ROCK

INCLINED FOR RAMPS AND STAIRWAYS
THROUGH LAYERS OF TAFLA

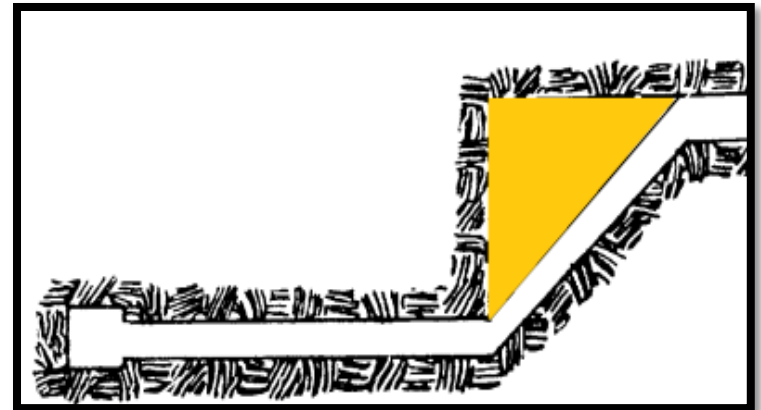
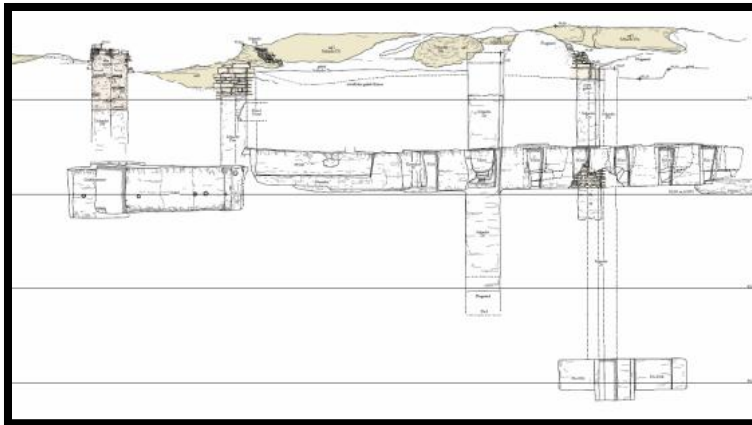
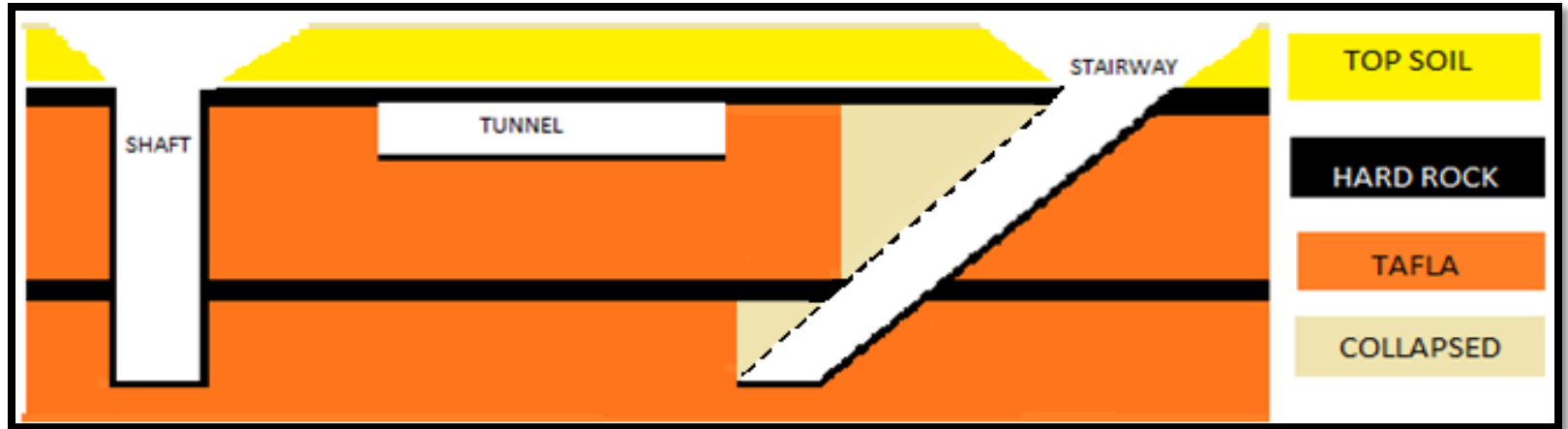

EPITOME

BURIAL CHAMBERS AT THE
BOTTOM OF SHAFTS

WERE ROOFED WITH
WOODEN-BEAMS, FLAT MEGALITHS,
CORBELLED STONE, OR GABLE
MEGALITHS
SUCCESSIVELY!

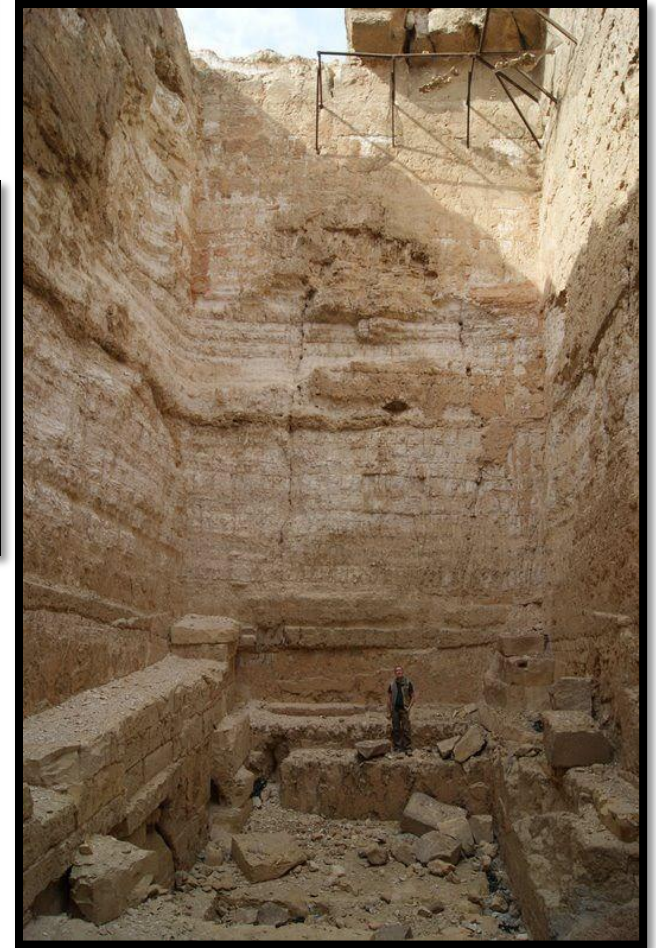
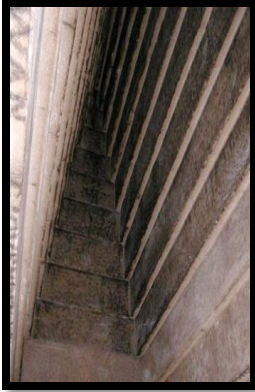

EPITOME

THE BURIAL-ROCK-CUT-CHAMBER OF THE
BRICK PYRAMID LEPSIUS 1
HAD THE FIRST
WESTERLY DISPOSED PLAN
WHICH WAS REPEATED AT ALL PYRAMIDS UNTIL KHUFU

ITS ENTRANCE,
HIGH UP ON THE NORTH SIDE
WAS FOLLOWED BY THE PYRAMIDS OF MEIDUM AND DAHSHUR

2 REASONS SUPPORT DATING THE
BRICK PYRAMID AT ABU RAWASH
TO THE THIRD DYNASTY

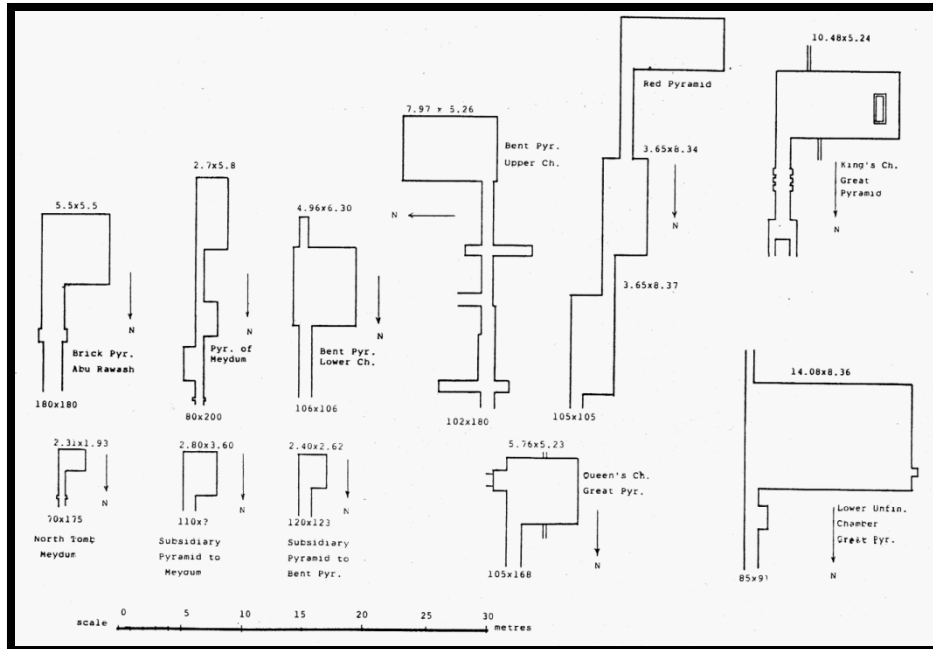
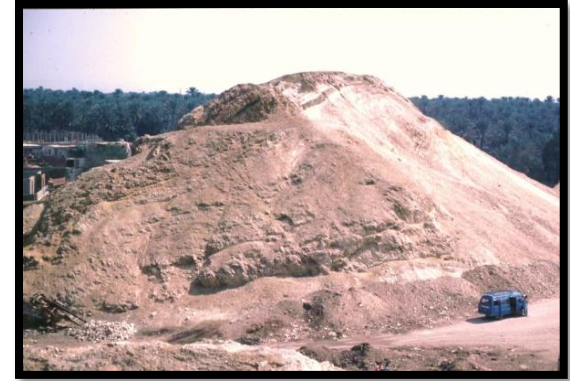
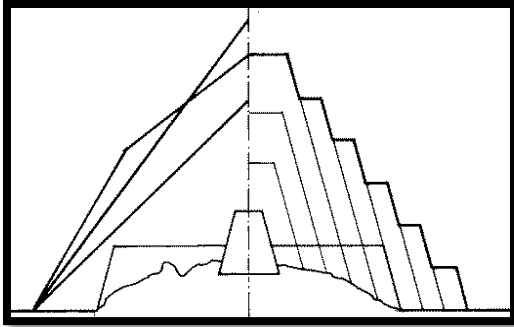

EPITOME

THE ROOF OF ZAWYET EL ARYAN NORTH SHAFT WOULD BE LIKE THE STEP AND SOUTHERN TOMB

A DEVELOPING DESIGN OF AN OVAL SARCOPHAGUS

A DESCENDING CORRIDOR SHAPE PREPARED FOR AN ACCRETION WEDGE BLOCKAGE

3 REASONS SUPPORT DATING THE PYRAMID AT ZAWYET EL ARYAN NORTH TO THE THIRD DYNASTY

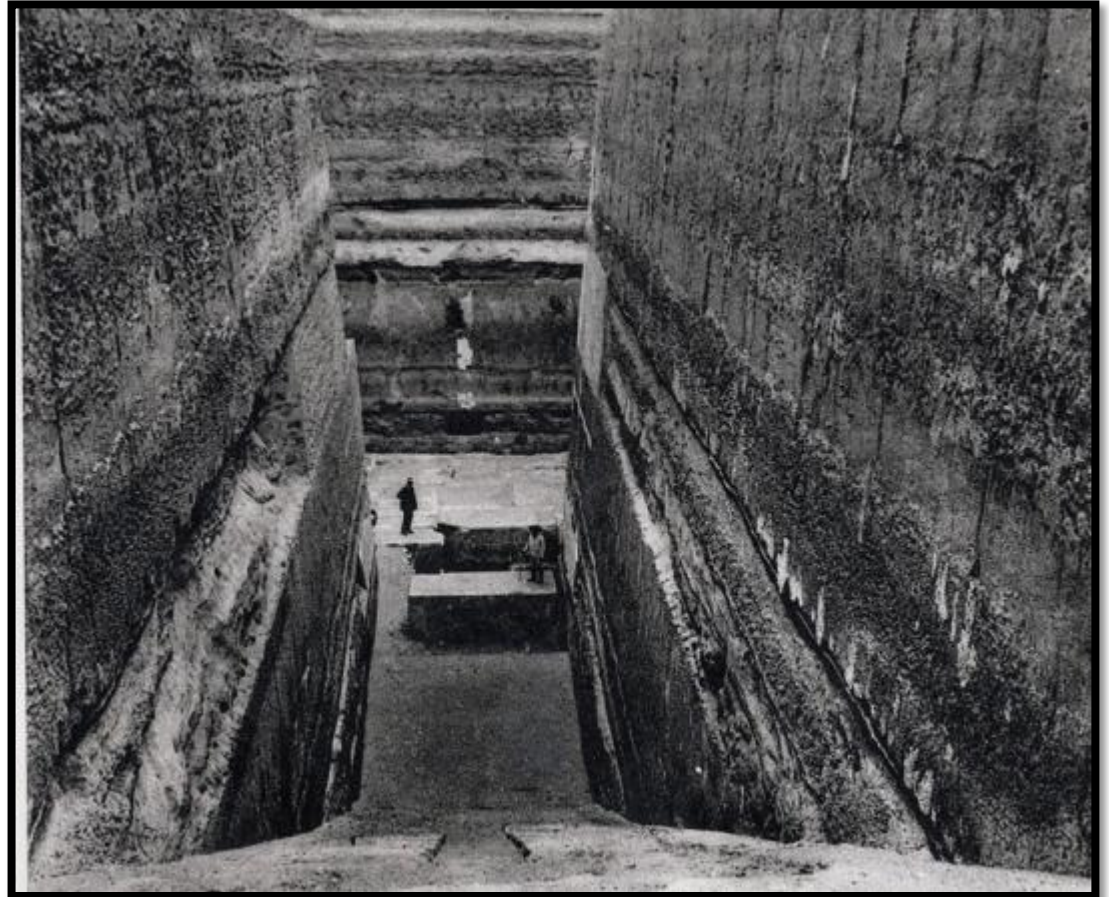

EPITOME

WHAT WERE THE REASONS FOR?

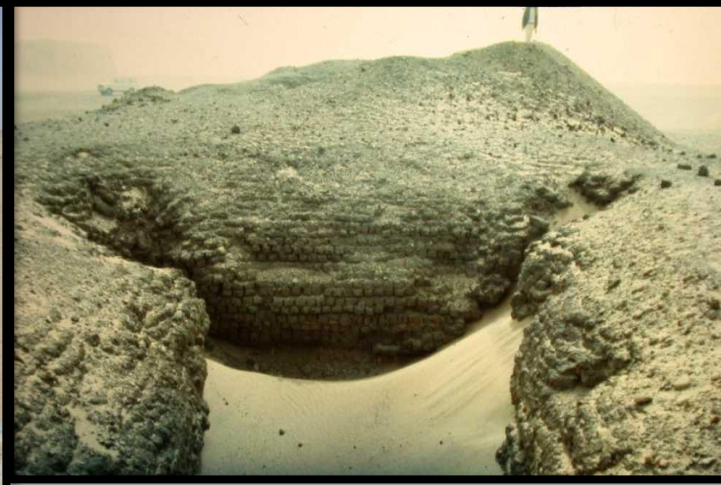

INDEPENDENT
SUBSTRUCTURES

PORTCULLIS
ONLY AT BET KHALLAF
AND HILL-SIDE

BOAT PITS
NOT FOUND

HILL-SIDE
HOW CAN ONE DEFINE

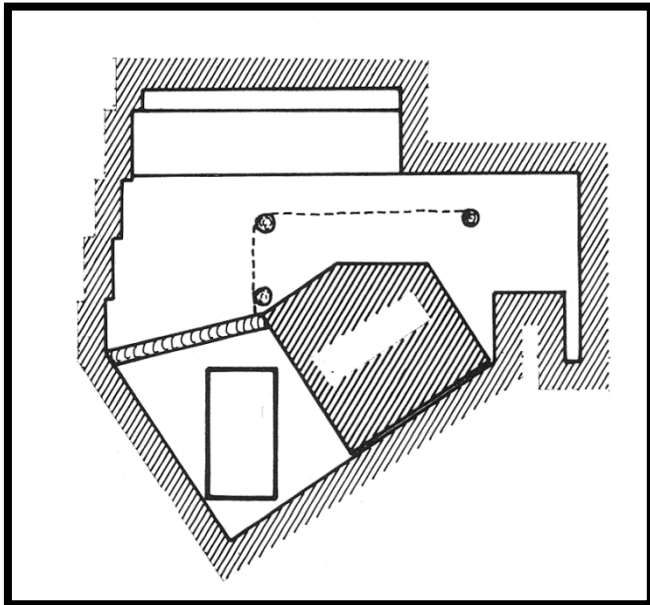

EPITOME

CHRONOLOGY OF THE SECOND DYNASTY



9 NAMES ON THE SAQQARA KING
9 NAMES IN THE MANETHONIAN TRADITION
6 NAMES ON THE ABYDOS KING LIST
6 NAMES DISCOVERED IN SEREKHS

4 TOMBS AT SAQQARA AND UMM EL QA^CAB

MORE ROYAL TOMES
MAY EXIST AT THE INNER SOUTH CHANEL WHICH HAD
INTERRUPTED
EARLIER UNIDENTIFIED TUNNELS



EPITOME

CHRONOLOGY OF THE SECOND DYNASTY RECORDS

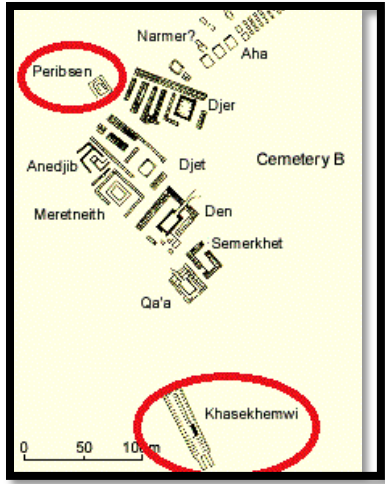
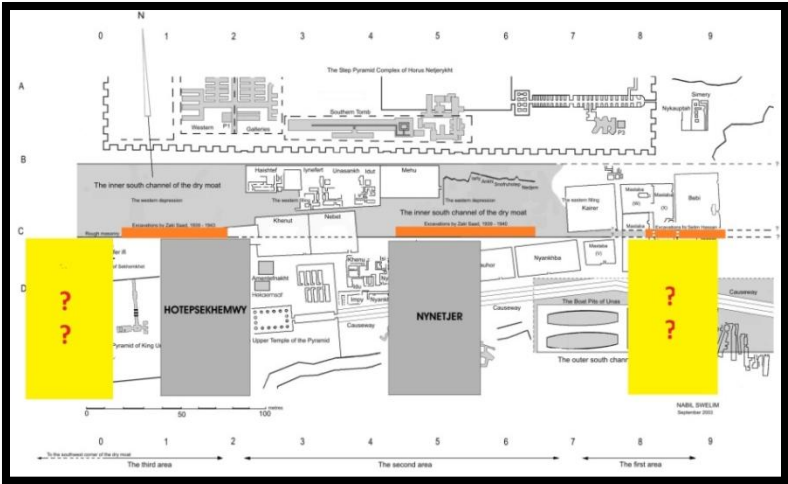

EPITOME

UNAS CLEARED

THE SUPERSTRUCTURES OF THE SECOND DYNASTY.

HIS CAUSEWAY WAS BUILT ON A DIKE FILLING
THE OUTER SOUTH CHANNEL

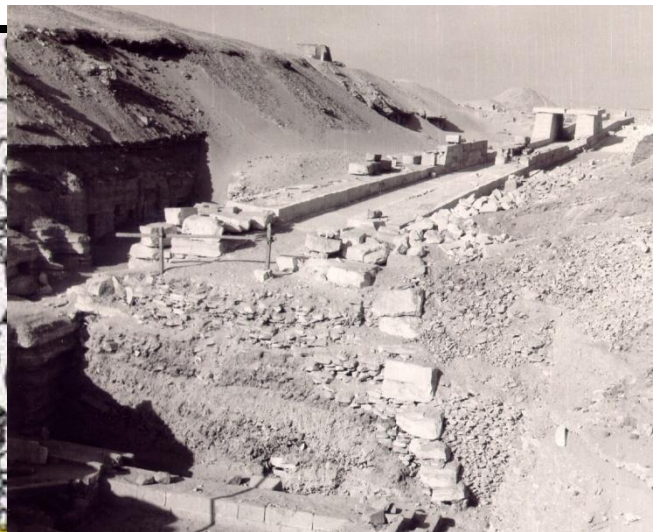
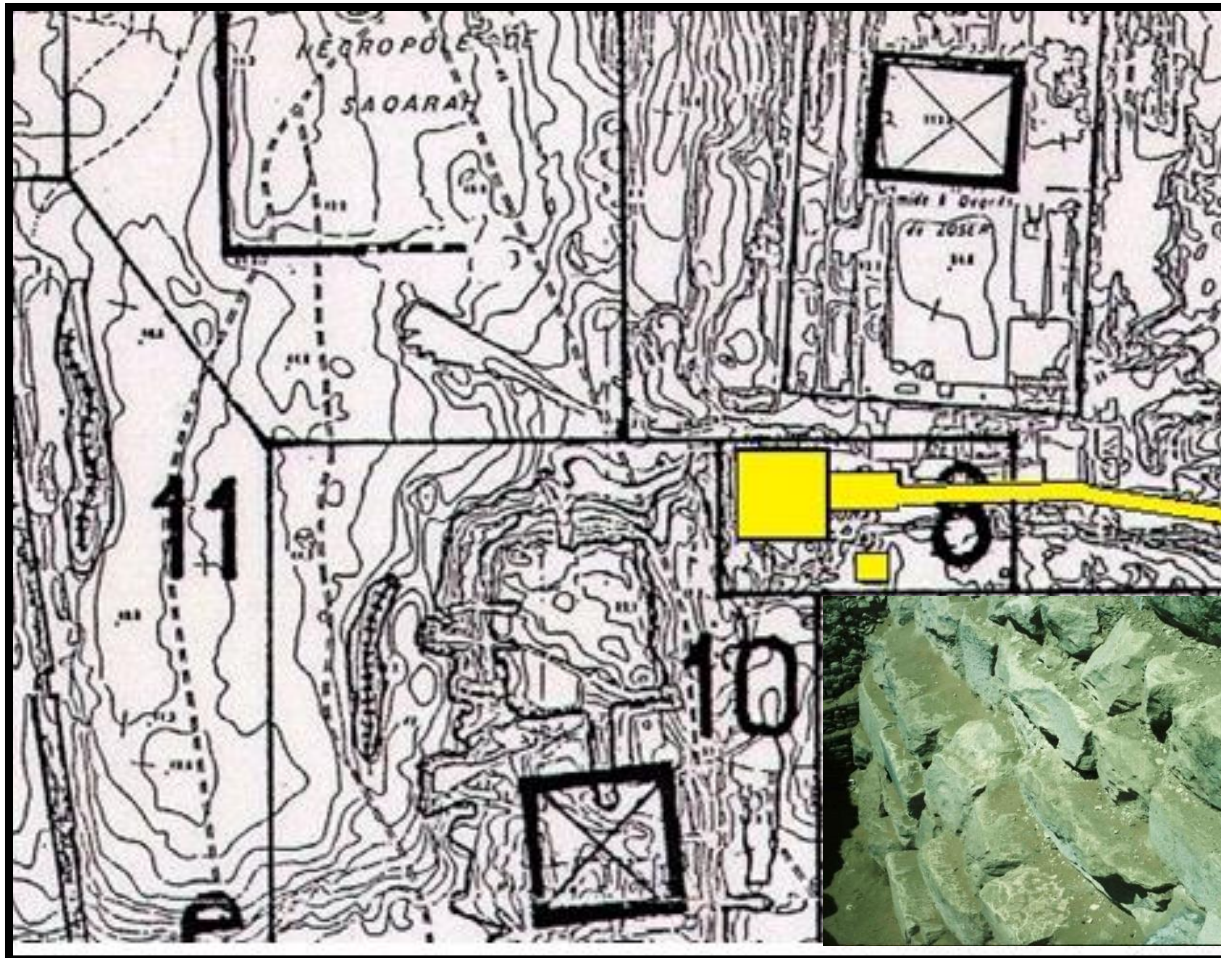

MAY GOD REST THEIR SOULS



ALAN GARDINER

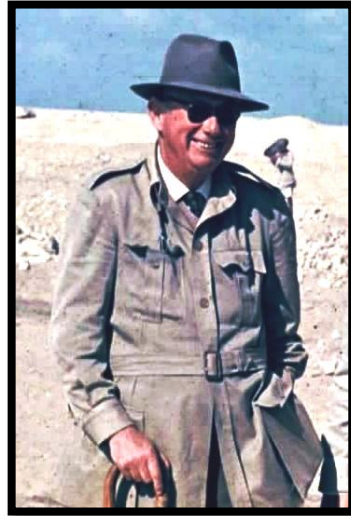

WALTER EMERY



J-PH LAUER



WERNER KAISER



LASZLO KAKOSY

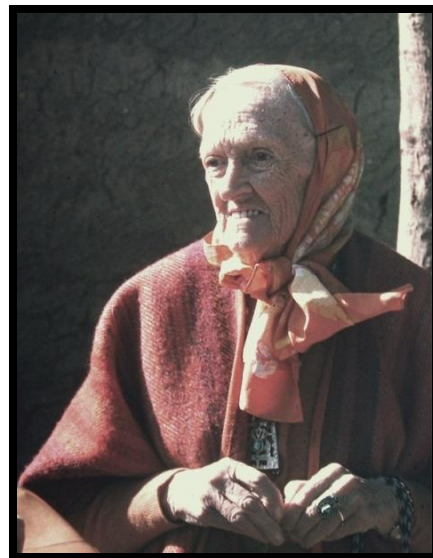

OMM SETY

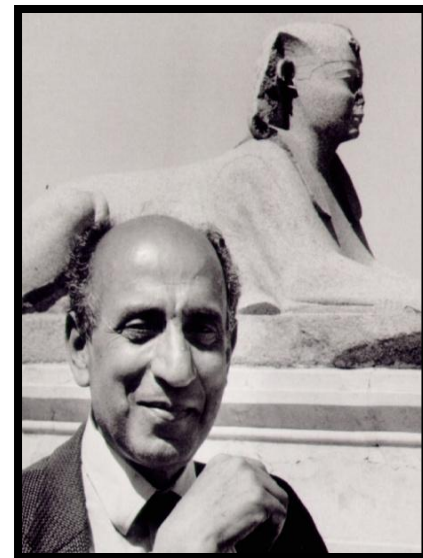

DAOUD ABDU